

London Housing Design Guide

INTERIM EDITION



MAYOR OF LONDON

Design for London
August 2010

Published by
London Development Agency
Palestra
197 Blackfriars Road
London SE1 8AA
www.lda.gov.uk
enquiries 020 7593 9000
text phone 020 7593 8001

This report is available online at:

<http://www.lda.gov.uk/publications-and-media/publications/design-guide.aspx>

http://www.designforlondon.gov.uk/uploads/media/Interim_London_Housing_Design_Guide.pdf

Contents

Foreword	04
Introduction	05
Development of the London Housing Design Guide	08
Using the Guide	09
Summary Table of London Housing Design Guide Standards	11
 Standards	
1.0 Shaping Good Places	18
2.0 Housing for a Diverse City	26
3.0 From Street to Front Door	32
4.0 Dwelling Space Standards	44
5.0 Home as a Place of Retreat	62
6.0 Climate Change Mitigation and Adaptation	70
7.0 Managing the Design Process	80
 Appendices	
1 Space Standards Study	92
2 Furniture Schedule	94
3 Wheelchair Accessible Housing Design Standards	96
4 Definitions	102
5 References	103

Foreword

The finest city in the world deserves the finest housing.

In building London's future we reflect on a past that has created some of the best buildings and urban spaces to be found anywhere in the world.

More recently, though, too much of our new housing has sacrificed space and quality to unit numbers. New homes in London are some of the smallest in Western Europe and this is indefensible. I am determined to see a new generation of standards which improve London's housing and we have a unique opportunity to deliver these now. If we are to renew the capital's tradition of design excellence, we must understand the thinking behind the city's design achievements and its failures. This understanding will ensure that we create homes people want to live in and in which they and their families can flourish, now and in the future.

My London Housing Strategy promotes excellence in design quality and sustainability. This guide underpins that commitment and is the first step to making it a reality. The strengthening collaboration between the London Development Agency and the Homes and Communities Agency has brought together the largest sources of funding for social housing and urban regeneration in the capital. The design standards set out in this guide will be applied immediately to LDA supported projects. I am also pleased that the HCA London Board has agreed that the new standards will be applied to new schemes applying for funding from April 2011 and to all tenures on its own land holdings. I encourage all

others involved in the creation of new homes to embrace this guidance.

My draft replacement London Plan is taking this challenge forward across all tenures. It incorporates a range of policies and guidance for housing design, including a new generation of minimum space standards. This will be supported by detailed supplementary guidance on housing to support implementation.

I have considered carefully the wide range of comments from all sectors of the development industry, submitted to me during the public consultation process on the draft guide. This interim edition is my response, and it sets out and explains my aspirations for the design of new housing in London. As well as applying to LDA supported projects, it signposts my aspirations to improve the quality of the design of homes in London, which will be carried forward through HCA funding requirements, the replacement London Plan and its associated supplementary guidance.

Above all, the objective of this guidance is not only to 'deliver housing units' but to provide beautiful and appropriate homes of the highest quality that respond to the complex design challenges posed by this most dynamic of cities.



Boris Johnson, Mayor of London

Introduction

This interim edition of the Mayor's London Housing Design Guide (LHDG) has been revised following public consultation on the draft LHDG in 2009 and the findings of a cost and delivery impact analysis. It is being published to show the direction of travel of the final guide, to shape the design of London Development Agency (LDA) supported developments, and to encourage all involved in the design of new housing to embrace the Mayor's aspirations.

The guide is not a statement of planning policy. Planning guidance for all housing tenures is contained in the draft replacement London Plan and its draft Supplementary Planning Guidance on Housing. The final guide will be issued following the finalisation of the Homes and Communities Agency's (HCA) consultation on its Proposed Core Housing Design and Sustainability Standards and the draft replacement London Plan Examination in Public, incorporating any necessary changes arising from these processes to ensure all design guidance is in alignment.

At the core of the guide are new minimum space standards. The guide also advocates improvements in the development and procurement processes so that design remains valued from vision to delivery. Together these support the Mayor's aspiration to help build a better, more humane and more beautiful city, with great housing at its heart.

The Challenge of London

This is a guide for London, and takes into account the diversity and complexity of its built environment and its social composition.

London's population is projected to grow to 8.8 million by 2031, and this promises to keep demand for housing high. At the same time London aspires to become a world leader in tackling climate change, and currently faces the uncertainty of gradual recovery from recession. The ambition to improve the quality of life for Londoners and the quality of the city's places and spaces is a particular challenge against this background.

The Design Challenge: A New London Vernacular

We are building places to live in a city with unique character, with examples of great housing and city-making at a range of densities. London's terraced houses, apartment buildings, streets, squares and the best of 20th century development have created highly successful residential environments with enduring appeal. This guide aspires to encourage a new London vernacular that can take its place in this rich fabric.

A new vernacular does not propose a singular architectural style, but recognises that the best housing comes from robust guidelines in planning and regulation, together with a deep understanding of particular architectural and social contexts on the part of designers and developers.

There are certain qualities that characterise the best parts of London that this guidance seeks to encourage. London has many great urban places created by housing. We want to encourage housing that has a clear and sophisticated urban intention, and improves and civilises the streets and public spaces around it.

» Introduction *continued*

London in general has a street-based urban arrangement. Essential to successful housing is an understanding of the hierarchy of streets in an area. Some are vital and busy, others are quieter. Good housing should add to the continuous, connected urban fabric of London. All this demands great design to successfully deliver.

The best areas of housing in London very often have strong and singular characters, often because of a consistent architectural expression and the widespread use of high-quality materials. In general, London's housing should not be striving for 'iconic' architecture, but should focus on great background architecture made of durable materials that weather well.

There is a demand in London for diverse dwelling types, and this guide describes how these can be mixed together without segregation by type or tenure, to make places where everyone can feel a sense of belonging. In recent years, some less successful trends have emerged in the development industry. In building so many over-dense apartment blocks with internal corridors serving small, single-aspect dwellings, we have risked creating a damaging legacy for future generations.

A fundamental aim of this guidance is to ensure that London's housing is flexible and accessible in use and adaptable over the life of a building. Housing should support family life, both in the flexibility and adaptability of homes and in the provision, in greater quantities, of larger homes. The minimum space standards in this guide aim to ensure that homes have the long-term adaptability to suit growing

families or new owners and tenants.

New dwellings must be accessible to the widest possible range of people at all stages of life, including disabled and older people. The ability to quickly and cheaply adapt a home when our circumstances change is particularly important in an ageing society where many of us want to maintain our quality of life, maximise our independence and stay in our own homes for as long as possible.

This guide also recognises that quality of detail is essential to really successful housing, and should not be seen as secondary to good urban planning or the arrangement of dwellings. Beautiful doors, ceramic tiles, elegant balustrades – little details like these can help housing developments go beyond the perfunctory, and add delight and dignity to people's daily lives.

Housing Standards

Housing standards have been used in the past to effect a step change in housing quality. The best known set of UK housing standards is the 1961 report 'Homes for Today and Tomorrow' by the Parker Morris Committee, the primary concern of which was to ensure that every 'council-built' home had enough space, along with satisfactory heating and sanitation.

Today the priority of providing adequate space and amenity is the same, but attention has rightly turned to the quality of provision across all tenures, and whether dwellings are fit for all. In recent years London has been providing some of the smallest homes in the developed world and too many developments of a low quality.

This is not something to be proud of and is not sustainable. The new London standards and guidance are intended to encourage provision of enough space in dwellings to ensure homes can be flexibly used by a range of residents. They also aim to ensure that space can be sensibly allocated to different functions, with adequate room sizes and storage integrated into the planning.

We must also use water, fuel and other limited resources in the most efficient way possible, to reduce carbon emissions and minimise the environmental impact of new development.

Standards alone are no guarantee of quality; they must be underpinned by robust forms of procurement and long-term management plans. Section 7, Managing the Design Process, deals with the development process to help ensure that the best design intentions are delivered on the ground.

The last decade has seen an array of design guidance issued by a variety of agencies. As a result, there is more emphasis than ever on excellence in design and sustainability and that is to be welcomed. This design guide does not aim to add yet another layer of policies and advice, but is derived from existing best practice guidelines, simplified and adapted to fit the capital's needs.

Development of the London Housing Design Guide

This document has been developed by Design for London and the LDA, with the involvement of the GLA and HCA London. The extensive process has included input from a variety of public sector investment partners, key external stakeholders such as Registered Social Landlords (RSLs) and private house builders, expert consultants, and a core group of respected housing architects and other industry experts.

The first stage in developing the guidance was to review in detail existing design standards and policies – the London Plan, the draft London Housing Strategy, the HCA's Housing Quality Indicators, the Code for Sustainable Homes and others – to identify overlaps and conflicts between existing standards. The development of the guide focused too, on identifying new requirements that would make a difference to the quality of housing.

The most significant of these is the minimum space standards, and to ensure these are robust, a new evidence base was established. This incorporates the Lifetime Homes standard and basic furniture and activity spaces derived from the HCA's Housing Quality Indicators. This ensures that the space standards are founded on tried and tested good practice principles.

The guide is based around six key themes. The structure of the themes starts at the scale of a neighbourhood then focuses on the individual home. These are:

- **1.0 Shaping Good Places:** integrating the development within the wider public realm network, providing opportunities for access to open and green space, and ensuring that development enhances

the existing character of the area.

- **2.0 Housing for a Diverse City:** designing for a mix of housing sizes, types and tenures, at appropriate densities.
- **3.0 From Street to Front Door:** guidance on the design of shared circulation areas and the entrance and approach to a group of flats or individual dwelling.
- **4.0 Dwelling Space Standards:** new minimum space standards and guidance on the size and layout of different rooms, including minimum sizes for storage and private outdoor space.
- **5.0 Home as a Place of Retreat:** design guidance for privacy, dual aspect dwellings, noise, floor-to-ceiling heights, daylight and sunlight.
- **6.0 Climate Change Mitigation and Adaptation:** clarifying the London approach to the implementation of the Code for Sustainable Homes in relation to London Plan policy.

The Consultation Process

The draft LHDG was published for public consultation in July 2009. This produced a constructive and wide-ranging debate on the implications of the guide for the future of housing developments in London. There was overall support for the aspirations of the draft: to encourage good design and to deliver high-quality, well-designed homes built to a high standard. The Mayor has carefully considered the responses received and the findings of the cost impact analysis commissioned by the HCA, GLA and LDA. The changes made to the draft London Housing Design Guide reflect a balance between achieving high quality housing against the objective of increasing the overall supply of housing in London.

Using the Guide

What is the purpose of this edition?

This interim edition of the Mayor's London Housing Design Guide (LHDG) follows the cost impact assessment and the public consultation on the draft LHDG. It shows the Mayor's ambition for excellent housing design and indicates the direction of travel for the final guide. A final version of the guide will align with the new London Plan and Housing Supplementary Planning Guidance and the HCA design standards review.

Who is the Mayor's Interim LHDG intended for?

This document is primarily addressed to housing developers, RSLs, architects, and borough planning officers in London. In the first instance the Mayor will require that the full content of the Interim LHDG be applied to developments that are supported by the LDA or on LDA land. However, others are encouraged to embrace the guidance and support the Mayor's ambition to improve the quality of housing in London.

Which existing policy, standards and guidelines have been incorporated in the LHDG?

The LHDG incorporates proposed London Plan policy, the Lifetime Homes standards (2010 edition), and the key components of Building for Life, Secured by Design and the Code for Sustainable Homes, and it also draws on other good practice guidance. The standards of the GLA Best Practice Guide for Wheelchair Accessible Housing are incorporated in appendix 3.

How is the Mayor's LHDG intended to be read?

The summary table in the next section offers

a quick reference to the standards, and the text in each section of the document provides a comprehensive explanation of what they seek to achieve and how they can be implemented. The LHDG is intended to be read in full at the earliest stages of a project and used from early conceptual design and capacity testing through to full planning and detailed design.

The guide is clear that good results rely on a good process as well as good design. Section 7 of this document offers advice on managing the design and development process in order to deliver successful schemes.

What is the difference between 'Priority 1' and 'Priority 2' standards?

It is expected that all developments supported by the LDA will meet the full range of standards set out in this guide. The standards in the draft Housing Supplementary Planning Guidance (SPG) of the draft replacement London Plan are aligned with the standards in this guide and are categorised as either 'Priority 1' or 'Priority 2' standards. 'Priority 1' standards must be met in full, while 'Priority 2' standards are strongly recommended as best practice but not required.

How does the LHDG relate to the draft SPG of the draft replacement London Plan (DRLP)?

This guide complements these documents, but does not, in itself, constitute either a statement of planning policy or Supplementary Planning Guidance. The guide illustrates the exemplary application of standards contained in the draft Housing SPG and the DRLP. It encourages designers

» Using the Guide *continued*

to produce housing of the highest quality and not just an acceptable standard.

How does the LHDG relate to the new HCA standards?

The HCA London Board, which is chaired by the Mayor, has agreed the objective of achieving a set of funding design standards in London, which align with the requirements of the London Housing Design Guide and Housing SPG.

The funding standards for the HCA in London will draw on the draft core national HCA standards framework and be supplemented by additional requirements, which bring these into alignment with the standards in the LHDG and Housing SPG. These standards will begin to be applied to funding decisions from April 2011. They will become mandatory for funding from April 2012. Reference should be made to HCA London for information on how the standards will be interpreted into funding requirements.

What are the next steps?

The final version of this guide will be published after the end of the DRLP Examination in Public and the finalisation of the HCA's Proposed Core Housing Design and Sustainability standards and the DRLP and Housing SPG.

In the intervening time, the guidance in the LHDG will continue to be refined, incorporating any changes arising from these processes. The Mayor is committed to ensuring the housing design standards of the Housing SPG, the final LHDG and the HCA London will be in full alignment

Summary Table of London Housing Design Guide Standards

1.0	Shaping Good Places	Priority 1	Priority 2
1.1	Defining Places		
1.1.1	Development proposals should demonstrate: <ul style="list-style-type: none"> • how the design responds to its physical context, including the character and legibility of the area and the local pattern of building, public space, landscape and topography; • how the scheme relates to the identified character of the place and to the local vision and strategy or how bolder change is justified in relation to a coherent set of ideas for the place expressed in the local vision and strategy or agreed locally. 	✓	
1.1.2	Development proposals should demonstrate: <ul style="list-style-type: none"> • how the scheme complements the local network of public spaces, including how it integrates with existing streets and paths; • how public spaces and pedestrian routes are designed to be overlooked and safe, and extensive blank elevations onto the public realm at ground floor have been avoided; • for larger developments, how any new public spaces including streets and paths are designed on the basis of an understanding of the planned role and character of these spaces within the local movement network, and how new spaces relate to the local vision and strategy for the area. 	✓	
1.2	Outdoor Spaces		
1.2.1	Development proposals should demonstrate that they comply with the borough's open space strategies, ensuring that a review of surrounding open space is undertaken and that opportunities to address a deficiency in provision by providing new public open spaces are taken forward in the design process.	✓	
1.2.2	For developments with a potential occupancy of ten children or more, development proposals should make appropriate play provision in accordance with the London Plan SPG, Providing for Children and Young People's Play and Informal Recreation.	✓	
1.2.3	Where communal open space is provided, development proposals should demonstrate that the space: <ul style="list-style-type: none"> • is overlooked by surrounding development; • is accessible to wheelchair users and other disabled people; • is designed to take advantage of direct sunlight; • has suitable management arrangements in place. 	✓	

2.0	Housing for a Diverse City	Priority 1	Priority 2
2.1	Appropriate Density		
2.1.1	Development proposals should demonstrate how the density of residential accommodation satisfies London Plan policy relating to public transport accessibility level (PTAL) and the accessibility of local amenities and services, and is appropriate to the location in London.	✓	
2.2	Residential Mix		
2.2.1	Development proposals should demonstrate how the mix of dwelling sizes and the mix of tenures meet strategic and local borough targets and are appropriate to the location in London.	✓	

3.0	From Street to Front Door	Priority 1	Priority 2
3.1	Entrance and Approach		
3.1.1	All main entrances to houses, ground floor flats and communal entrance lobbies should be visible from the public realm and clearly identified.	✓	
3.1.2	The distance from the accessible car parking space of requirement 3.3.4 to the home or to the relevant block entrance or lift core should be kept to a minimum and should be level or gently sloping [Lifetime Homes Criterion 2].	✓	
3.1.3	The approach to all entrances should preferably be level or gently sloping [Lifetime Homes Criterion 3].	✓	
3.1.4	All entrances should be illuminated and have level access over the threshold. Entrance doors should have 300mm of clear space to the pull side, and clear minimum opening widths of 800mm or 825mm depending on the direction and width of approach. Main entrances should have weather protection and a level external landing [Lifetime Homes Criterion 4].	✓	
3.2	Shared Circulation Within Buildings		
3.2.1	The number of dwellings accessed from a single core should not exceed eight per floor.		✓
3.2.2	An access core serving 4 or more dwellings should provide an access control system with entry phones in all dwellings linked to a main front door with electronic lock release. Unless a 24 hour concierge is provided, additional security measures including audio-visual verification to the access control system should be provided where any of the following apply: <ul style="list-style-type: none"> • more than 25 dwellings are served by one core • the potential occupancy of the dwellings served by one core exceeds 100 bed spaces • more than 8 dwellings are provided per floor. 	✓	
3.2.3	Where dwellings are accessed via an internal corridor, the corridor should receive natural light and adequate ventilation.	✓	
3.2.4	The minimum width for all paths, corridors and decks for communal circulation is 1200mm. The preferred minimum width is 1500mm, and is considered particularly important where corridors are double loaded (they serve dwellings on each side) and where wheelchair accessible dwellings are provided.	✓	
3.2.5	For buildings with dwellings entered from communal circulation at the first, second or third floor where lifts are not provided, space should be identified within or adjacent to the circulation cores for the future installation of a wheelchair accessible lift.		✓
3.2.6	All dwellings entered at the fourth floor (fifth storey) and above should be served by at least one wheelchair accessible lift, and it is desirable that dwellings entered at the third floor (fourth storey) are served by at least one such lift. All dwellings entered at the seventh floor (eighth storey) and above should be served by at least two lifts.	✓	
3.2.7	Every designated wheelchair accessible dwelling above the ground floor should be served by at least one wheelchair accessible lift. It is desirable that every wheelchair accessible dwelling is served by at least two such lifts.	✓	
3.2.8	Principal access stairs should provide easy access* regardless of whether a lift is provided. Where homes are reached by a lift, it should be fully wheelchair accessible [Lifetime Homes Criterion 5].	✓	
3.3	Car Parking		
3.3.1	All developments should conform to London Plan policy on car parking provision. In areas of good public transport accessibility and/or town centres the aim should be to provide less than one space per dwelling. Elsewhere parking provision should be as follows: <ul style="list-style-type: none"> • 4+ bedroom dwellings: 1.5 - 2 spaces per dwelling; • 3 bedroom dwellings: 1 - 1.5 spaces per dwelling; • 1 - 2 bedroom dwellings: less than 1 per dwelling. 	✓	
3.3.2	Each designated wheelchair accessible dwelling should have a car parking space 2400mm wide with a clear access way to one side of 1200mm. Refer to appendix 3 for design standards for wheelchair accessible housing.	✓	

3.3.3	Careful consideration should be given to the siting and organisation of car parking within an overall design for open space so that car parking does not negatively affect the use and appearance of open spaces.	✓	
3.3.4	Where car parking is within the dwelling plot, at least one car parking space should be capable of enlargement to a width of 3300mm. Where parking is provided in communal bays, at least one space with a width of 3300mm should be provided per block entrance or access core in addition to spaces designated for wheelchair user dwellings [Lifetime Homes Criterion 1].	✓	
3.4	Cycle Storage		
3.4.1	All developments should provide dedicated storage space for cycles at the following levels: <ul style="list-style-type: none"> • 1 per 1 or 2 bedroom dwelling; or • 2 per 3 or more bedroom dwelling 	✓	
3.4.2	Individual or communal cycle storage outside the home should be secure, sheltered and adequately lit, with convenient access to the street. Where cycle storage is provided within the home, it should be in addition to the minimum GIA and minimum storage and circulation space requirements. Cycle storage identified in habitable rooms or on balconies will not be considered acceptable.		✓
3.5	Refuse, Post and Deliveries		
3.5.1	Communal refuse and recycling containers, communal bin enclosures and refuse stores should be accessible to all residents including children and wheelchair users, and located on a hard, level surface. The location should satisfy local requirements for waste collection and should achieve full credits under the Code for Sustainable Homes Technical Guide. Refuse stores within buildings should be located to limit the nuisance caused by noise and smells and provided with means for cleaning.	✓	
3.5.2	Storage facilities for waste and recycling containers should be provided in accordance with the Code for Sustainable Homes Technical Guide and local authority requirements.	✓	

4.0	Dwelling Space Standards	Priority 1	Priority 2																																						
4.1	Internal Floor Area																																								
4.1.1	<p>All developments should meet the following minimum space standards.</p> <table border="1"> <thead> <tr> <th></th> <th>Dwelling type (bedroom/ persons)</th> <th>Essential GIA (sq.m)</th> </tr> </thead> <tbody> <tr> <td rowspan="7">Single storey dwelling</td> <td>1b2p</td> <td>50</td> </tr> <tr> <td>2b3p</td> <td>61</td> </tr> <tr> <td>2b4p</td> <td>70</td> </tr> <tr> <td>3b4p</td> <td>74</td> </tr> <tr> <td>3b5p</td> <td>86</td> </tr> <tr> <td>3b6p</td> <td>95</td> </tr> <tr> <td>4b5p</td> <td>90</td> </tr> <tr> <td>4b6p</td> <td>99</td> </tr> <tr> <td rowspan="5">Two storey dwelling</td> <td>2b4p</td> <td>83</td> </tr> <tr> <td>3b4p</td> <td>87</td> </tr> <tr> <td>3b5p</td> <td>96</td> </tr> <tr> <td>4b5p</td> <td>100</td> </tr> <tr> <td>4b6p</td> <td>107</td> </tr> <tr> <td rowspan="3">Three storey dwelling</td> <td>3b5p</td> <td>102</td> </tr> <tr> <td>4b5p</td> <td>106</td> </tr> <tr> <td>4b6p</td> <td>113</td> </tr> </tbody> </table> <p>For dwellings designed for more than 6 people, at least 10 sq m gross internal area should be added for each additional person.</p>		Dwelling type (bedroom/ persons)	Essential GIA (sq.m)	Single storey dwelling	1b2p	50	2b3p	61	2b4p	70	3b4p	74	3b5p	86	3b6p	95	4b5p	90	4b6p	99	Two storey dwelling	2b4p	83	3b4p	87	3b5p	96	4b5p	100	4b6p	107	Three storey dwelling	3b5p	102	4b5p	106	4b6p	113	✓	
	Dwelling type (bedroom/ persons)	Essential GIA (sq.m)																																							
Single storey dwelling	1b2p	50																																							
	2b3p	61																																							
	2b4p	70																																							
	3b4p	74																																							
	3b5p	86																																							
	3b6p	95																																							
	4b5p	90																																							
4b6p	99																																								
Two storey dwelling	2b4p	83																																							
	3b4p	87																																							
	3b5p	96																																							
	4b5p	100																																							
	4b6p	107																																							
Three storey dwelling	3b5p	102																																							
	4b5p	106																																							
	4b6p	113																																							

4.1.2	Dwelling plans should demonstrate that dwellings will accommodate the furniture, access and activity space requirements relating to the declared level of occupancy. Refer to appendix 3 for design standards for wheelchair accessible housing.	✓													
4.2	Flexibility and Adaptability														
4.2.1	Dwelling plans should demonstrate that dwelling types provide flexibility by allowing for alternative seating arrangements in living rooms and by accommodating double or twin beds in at least one double bedroom.	✓													
4.3	Circulation in the Home														
4.3.1	<p>The minimum width of hallways and other circulation spaces inside the home should be 900mm. This may reduce to 750mm at 'pinch points' e.g. next to radiators, where doorway widths meet the following specification:</p> <table border="1" data-bbox="427 577 997 842"> <thead> <tr> <th>Minimum clear opening width of doorway (mm)</th> <th>Minimum approach width (when approach is not head on) (mm)</th> </tr> </thead> <tbody> <tr> <td>750</td> <td>1200</td> </tr> <tr> <td>775</td> <td>1050</td> </tr> <tr> <td>900</td> <td>900</td> </tr> </tbody> </table> <p>Where a hallway is at least 900mm wide and the approach to the door is head-on, a minimum clear opening door width of 750mm should be provided [Lifetime Homes Criterion 6].</p>	Minimum clear opening width of doorway (mm)	Minimum approach width (when approach is not head on) (mm)	750	1200	775	1050	900	900	✓					
Minimum clear opening width of doorway (mm)	Minimum approach width (when approach is not head on) (mm)														
750	1200														
775	1050														
900	900														
4.3.2	The design of dwellings of more than one storey should incorporate potential for a stair lift to be installed and a suitable identified space for a through-the-floor lift from the entrance level [†] to a storey containing a main bedroom and an accessible bathroom [Lifetime Homes Criterion 12].	✓													
4.4	Living, Dining and Kitchen Areas														
4.4.1	<p>The following combined floor areas for living / kitchen / dining space should be met:</p> <table border="1" data-bbox="427 1196 997 1559"> <thead> <tr> <th>Designed level of occupancy</th> <th>Minimum combined floor area of living, dining and kitchen spaces (sq m)</th> </tr> </thead> <tbody> <tr> <td>2 person</td> <td>23</td> </tr> <tr> <td>3 person</td> <td>25</td> </tr> <tr> <td>4 person</td> <td>27</td> </tr> <tr> <td>5 person</td> <td>29</td> </tr> <tr> <td>6 person</td> <td>31</td> </tr> </tbody> </table>	Designed level of occupancy	Minimum combined floor area of living, dining and kitchen spaces (sq m)	2 person	23	3 person	25	4 person	27	5 person	29	6 person	31		✓
Designed level of occupancy	Minimum combined floor area of living, dining and kitchen spaces (sq m)														
2 person	23														
3 person	25														
4 person	27														
5 person	29														
6 person	31														
4.4.2	The minimum width of the main sitting area should be 2.8m in 2-3 person dwellings and 3.2m in dwellings designed for four or more people.		✓												
4.4.3	Dwellings with three or more bedrooms should have two living spaces, for example a living room and a kitchen-dining room. Both rooms should have external windows. If a kitchen is adjacent to the living room, the internal partition between the rooms should not be load-bearing, to allow for reconfiguration as an open plan arrangement. Studies will not be considered as second living spaces.		✓												
4.4.4	There should be space for turning a wheelchair in dining areas and living rooms and basic circulation space for wheelchairs elsewhere [Lifetime Homes Criterion 7].	✓													
4.4.5	A living room, living space or kitchen-dining room should be at entrance level [Lifetime Homes Standard 8].	✓													

4.4.6	Windows in the principal living space should start 800mm above finished floor level (+/- 50mm) to allow people to see out while seated. At least one opening window should be easy to approach and operate by people with restricted movement and reach. [Lifetime Homes Criterion 15].	✓	
4.5	Bedrooms		
4.5.1	The minimum area of a single bedroom should be 8 sq m. The minimum area of a double or twin bedroom should be 12 sq m.		✓
4.5.2	The minimum width of double and twin bedrooms should be 2.75m in most of the length of the room.		✓
4.5.3	In homes of two or more storeys with no permanent bedroom at entrance level [†] , there should be space on the entrance level that could be used as a convenient temporary bed space [Lifetime Homes Criterion 9].	✓	
4.5.4	Structure above a main bedroom and an accessible bathroom should be capable of supporting a ceiling hoist and the design should allow for a reasonable route between this bedroom and bathroom [Lifetime Homes Criterion 13].	✓	
4.6	Bathrooms and WCs		
4.6.1	Dwellings designed for an occupancy of five or more people should provide a minimum of one bathroom with WC and one additional WC.		✓
4.6.2	Where there is no accessible bathroom at entrance level [†] , a wheelchair accessible WC with potential for a shower to be installed should be provided at entrance level [°] [Lifetime Homes Criterion 10].	✓	
4.6.3	An accessible bathroom should be provided in every dwelling on the same storey as a main bedroom [Lifetime Homes Criterion 14].	✓	
4.6.4	Walls in bathrooms and WCs should be capable of taking adaptations such as handrails ^{††} [Lifetime Homes Criterion 11].	✓	
4.7	Storage and Utility		
4.7.1	Built-in general internal storage space free of hot water cylinders and other obstructions, with a minimum internal height of 2m and a minimum area of 1.5 sq m should be provided for 2 person dwellings, in addition to storage provided by furniture in habitable rooms. For each additional occupant an additional 0.5 sq m of storage space is required.	✓	
4.8	Study and Work		
4.8.1	Dwelling plans should demonstrate that all homes are provided with adequate space and services to be able to work from home. The Code for Sustainable Homes guidance on working from home is recommended as a reference.	✓	
4.8.2	Service controls should be within a height band of 450mm to 1200mm from the floor and at least 300mm away from any internal room corner [Lifetime Homes Criterion 16].	✓	
4.9	Wheelchair User Dwellings		
4.9.1	Ten percent of new housing should be designed to be wheelchair accessible or easily adaptable for residents who are wheelchair users in accordance with the GLA Best Practice Guide, Wheelchair Accessible Housing. Refer to appendix 3 for design standards for wheelchair accessible housing.	✓	
4.10	Private Open Space		
4.10.1	A minimum of 5 sq m of private outdoor space should be provided for 1-2 person dwellings and an extra 1 sq m should be provided for each additional occupant.	✓	
4.10.2	Private outdoor spaces should have level access from the home ‡ [Lifetime Homes Criterion 4].	✓	
4.10.3	The minimum depth and width of all balconies and other private external spaces is 1500mm.	✓	

5.0	Home as a Place of Retreat	Priority 1	Priority 2
5.1	Privacy		
5.1.1	Design proposals should demonstrate how habitable rooms within each dwelling are provided with an adequate level of privacy in relation to neighbouring property and the street and other public spaces.	✓	
5.2	Dual Aspect		
5.2.1	Developments should avoid single aspect dwellings that are north facing, exposed to noise exposure categories C or D, or contain three or more bedrooms.	✓	
5.2.2	Where single aspect dwellings are proposed, the designer should demonstrate how good levels of ventilation, daylight and privacy will be provided to each habitable room and the kitchen.	✓	
5.3	Noise		
5.3.1	The layout of adjacent dwellings and the location of lifts and circulation spaces should seek to limit the transmission of noise to sound sensitive rooms within dwellings.	✓	
5.4	Floor to Ceiling Heights		
5.4.1	The minimum floor to ceiling height in habitable rooms is 2.5m between finished floor level and finished ceiling level. A minimum floor to ceiling height of 2.6m in habitable rooms is considered desirable and taller ceiling heights are encouraged in ground floor dwellings.	✓	
5.5	Daylight and Sunlight		
5.5.1	Glazing to all habitable rooms should be not less than 20% of the internal floor area of the room.		✓
5.5.2	All homes should provide for direct sunlight to enter at least one habitable room for part of the day. Living areas and kitchen dining spaces should preferably receive direct sunlight.		✓

6.0	Climate Change Mitigation and Adaptation	Priority 1	Priority 2								
6.1	Environmental Performance										
6.1.1	Designers should seek to achieve a minimum of Level 4 of the Code for Sustainable Homes in all new developments.		✓								
6.1.2	All homes should satisfy London Plan policy on sustainable design and construction and make the fullest contribution to the mitigation of and adaptation to climate change.	✓									
6.2	Energy and CO2										
6.2.1	Development proposals should be designed in accordance with the London Plan energy hierarchy, and should meet the following minimum targets for carbon dioxide emissions reduction. <table border="1" data-bbox="427 1532 995 1765" style="margin-left: auto; margin-right: auto;"> <thead> <tr> <th>Year</th> <th>Improvement on 2006 Building Regulations</th> </tr> </thead> <tbody> <tr> <td>2010 - 2013</td> <td>44 per cent</td> </tr> <tr> <td>2013 - 2016</td> <td>55 per cent</td> </tr> <tr> <td>2016 - 2031</td> <td>Zero carbon</td> </tr> </tbody> </table>	Year	Improvement on 2006 Building Regulations	2010 - 2013	44 per cent	2013 - 2016	55 per cent	2016 - 2031	Zero carbon	✓	
Year	Improvement on 2006 Building Regulations										
2010 - 2013	44 per cent										
2013 - 2016	55 per cent										
2016 - 2031	Zero carbon										
6.3	Overheating										
6.3.1	Development proposals should demonstrate how the design of dwellings will avoid overheating during summer months without reliance on energy intensive mechanical cooling systems.	✓									
6.4	Water										
6.4.1	New dwellings should be designed to ensure that a maximum of 105 litres of water is consumed per person per day.	✓									

6.4.2	Where development is permitted in an area at risk of flooding, it should incorporate flood resilient design in accordance with PPS25.	✓	
6.4.3	New development should adhere to standards for surface water run-off as set out in the Code for Sustainable Homes.	✓	
6.4.4	New development should incorporate Sustainable Urban Drainage Systems and green roofs where appropriate.	✓	
6.5	Materials		
6.5.1	All new residential development should meet the requirements of the Code Level 4 with regard to using materials with lower environmental impacts over their lifecycle.		✓
6.5.2	All new residential development should accord with Code for Sustainable Homes Level 4 and the London Sustainable Design and Construction SPG with regard to the sourcing of materials.	✓	
6.6	Ecology		
6.6.1	The design and layout of new residential development should avoid areas of ecological value and seek to enhance the ecological capital of the area in accordance with GLA best practice guidance on biodiversity and nature conservation.	✓	

* In the Lifetime Homes Criteria a stair providing easy access is defined as one having maximum risers of 170mm, minimum goings of 250mm and a minimum width of 900mm measured 450mm above the pitch line.

† In the Lifetime Homes Criteria the entrance level of a dwelling is generally deemed to be the storey containing the main entrance door. Where there are no rooms on the storey containing the main entrance door (e.g. flats over garages or shops and some duplexes and townhouses) the first storey level containing a habitable or non-habitable room can be considered the entrance level, if this storey is reached by a stair providing 'easy access', as defined above.

‡ Balconies and terraces over habitable rooms which require a step up to increase slab thickness / insulation are exempt from the Lifetime Homes level access standard.

° Dwellings over more than one storey with no more than two bedrooms may instead be designed with a Part M compliant WC at entrance level. The WC should provide a floor drain to allow for an accessible shower to be installed at a later date.

†† Adequate fixing and support for grab rails should be available at any location on all walls within a height band of 300mm - 1800mm from the floor.

1.0

Shaping Good Places

The Mayor wants London's new housing to shape great places in the city, places people can identify with, which raise the spirit and represent the aspirations and ambitions of our times. Housing is seldom about making iconic buildings that are at odds with their contexts. New houses and apartment buildings will be the lasting background to our daily lives. They should be a pleasure for people to walk past

every day, through their civility, quality of materials, character and generosity towards the public realm.

Housing makes up the majority of the city's built environment and we have an opportunity to create a beautiful and enduring legacy of homes that belong in London, and nowhere else.

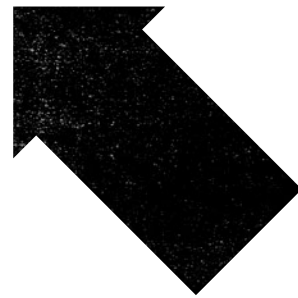
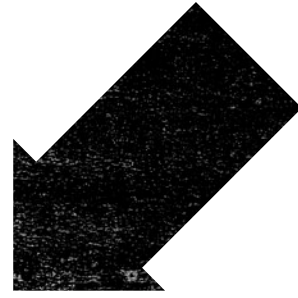
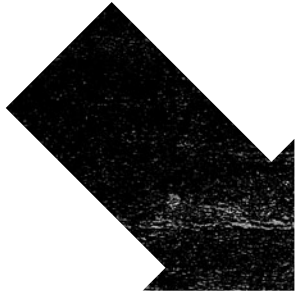



1.1

Defining Places

Character and Context

The best developments are those designed with a sensitive understanding of their urban context, valuing the characteristics of the place and community.

It matters how our housing looks. Each building plays a part in the city and its architecture should contribute to the character of a part of London. The most successful residential areas in London generally have a strong and consistent architectural character.

New developments often struggle to make coherent places. Because of this, the Mayor encourages a design approach that carefully responds to the whole context of a development and builds on an understanding of the place, the observation of existing assets, and the local authority's existing vision or spatial strategy for the area. Through the designer's choice of scale, material, massing and building type, development should respect the existing character and urban grain of a place and build on the positive elements.

Where a spatial strategy is already in place, this should be respected, and designers should demonstrate how new development contributes to the vision and strategy for the area. Where no such guidance is in place, those who propose bolder change should undertake an inclusive process that allows for a coherent vision for the future of the area to be developed and realised.

Well-connected and Legible

Woven through the city is an intricate network of public spaces made up of streets, squares, paths, lanes, mews,

gardens and parks. This is the framework of London, allowing people to get where they want to go and to enjoy spending time outdoors in the city.

Parts of the city that work well have a safe network of connected spaces and routes for pedestrians, cyclists and vehicles that is easy to understand and navigate. Each new development should connect into and extend the surrounding network and show an understanding of the hierarchy of these routes.

Urban spaces are most successful when it is inherently clear who is meant to use them. It is important to ensure that outdoor spaces are inviting and accessible, and that they engender a sense of ownership amongst the people who are intended to use them. There should also always be clear distinctions between spaces that are for public and private use.

The arrangement of uses and the architectural expression of a development have a significant effect on the character of streets and public spaces, and whether or not they become well-loved and well-used spaces.

Placing entrances and windows on street frontages and around public spaces brings activity which in turn increases neighbourliness and security by passive surveillance¹. To those inside looking out, it also gives an important sense of belonging to the wider world. In contrast, when public spaces are flanked by extensive windowless elevations, exposed undercroft parking or refuse and cycle stores, this is at best a missed opportunity, and at worst a catalyst for anti-social behaviour.

Standards

1.1.1

Development proposals should demonstrate:

- how the design responds to its physical context, including the character and legibility of the area and the local pattern of building, public space, landscape and topography;
- how the scheme relates to the identified character of the place and to the local vision and strategy or how bolder change is justified in relation to a coherent set of ideas for the place expressed in the local vision and strategy or agreed locally.

1.1.2

Development proposals should demonstrate:

- how the scheme complements the local network of public spaces, including how it integrates with existing streets and paths;
- how public spaces and pedestrian routes are designed to be overlooked and safe, and extensive blank elevations onto the public realm at ground floor have been avoided;
- for larger developments, how any new public spaces including streets and paths are designed on the basis of an understanding of the planned role and character of these spaces within the local movement network, and how new spaces relate to the local vision and strategy for the area.



1.2 Outdoor Spaces

Designing housing always means making a new part of the public realm of the city. In all new housing we need to give as much consideration to the shape, scale and qualities of the spaces between buildings as to the buildings themselves.

Open space, particularly green open space, is especially valuable in the city. In addition to benefits to health and well-being, green space can also help London adapt to the effects of climate change by soaking up rainwater, attenuating flooding, and providing cooler environments. Sustainable urban drainage can also be achieved in hard external areas with permeable surfaces.

Designers and developers should undertake a review of existing open spaces in the area and take account of the requirements set by individual boroughs in their Local Development Frameworks (LDFs) and Open Space Strategies, based on the London Plan benchmark public open space hierarchy². New proposals for open space should respond to scale and setting, complement what exists and address deficiencies in local provision as well as serving new residents. Proposals are best negotiated with the local borough and opportunities for community involvement should always be explored.

Larger residential developments will need a landscape strategy which considers the full range of possible provision, including outdoor sport and play facilities, local parks and other public spaces.

Even small housing developments invariably provide an opportunity to add to the quality of the public realm through tree planting, street furniture and the

use of high quality materials, details and workmanship in streets and other spaces.

Communal spaces³ designed to be shared by a smaller group of residents can work well in small and large developments. The most successful examples are overlooked by the households that share the space, engendering a sense of ownership among residents.

Orientation is important. Spaces that receive some direct sunlight are used more frequently and enjoyed for longer periods throughout the year.

Enduring success depends heavily on good stewardship, and thought should be given, at the outset, to the way in which public and shared open spaces will be managed and maintained.

In the initial design stage of a project, great attention should be paid to the location and organisation of car parking, to ensure amenity space is preserved and the public realm is not dominated by parked cars. This can become a problem if not enough thought is given to the relationship between housing density, building type and the type of parking provision. Possibilities for on-site parking including undercroft and on-street parking should always be explored in preference to providing extensive open areas of surface car parking.

Play

Play is vital to child development. It is the means by which children explore ideas, learn social skills and make discoveries. The London Plan requires all development proposals including

housing to provide for play and informal recreation⁴. The appropriate size or type of play space (or spaces) will depend on the existing provision in the area, the size and make-up of the child population – including additional need created by the new housing – and the nature of the development in its context. Guidance is provided by the Mayor’s Supplementary Planning Guidance ‘Providing for Children

and Young People’s Play and Informal Recreation’. Where dedicated playgrounds are provided, designers should ensure that they are integrated with surrounding social spaces and buildings. Ensuring play spaces are overlooked and secure is vital to their success. Consideration should also be given to the access needs of disabled children and carers.

Summary of SPG Requirements

No. of children	10 – 29	30 – 49	50 – 79	80+
Size of space required	100-300 sq m	300-500 sq m	500 – 800 sq m	800 sq m +
Facilities for under 5s	On-site doorstep playable space	On site local playable space	On-site local playable space	On-site local or neighbourhood playable space
Facilities for 5-11s	Off-site within 400m			
Facilities for 12+	Off-site within 800m	Off-site within 800m	Off-site within 800m or on-site subject to size and local circumstances	On-site youth space
Possible variation to reflect existing provision	If area is deficient in play space for 5–11s, some on-site facilities should be provided	If area is within 400m of existing facilities for 5–11s, an off-site contribution may be considered if in accordance with Play Strategy	If area is deficient in spaces for 12+, some on-site facilities or new off-site provision should be provided within 800m	If area is within 800m of existing facilities for 12+, an off-site contribution may be considered if in accordance with Play Strategy

Standards

1.2.1

Development proposals should demonstrate that they comply with the borough's open space strategies, ensuring that a review of surrounding open space is undertaken and that opportunities to address a deficiency in provision by providing new public open spaces are taken forward in the design process.

1.2.2

For developments with a potential occupancy of ten children or more, development proposals should make appropriate play provision in accordance with the London Plan SPG, Providing for Children and Young People's Play and Informal Recreation.

1.2.3

Where communal open space is provided, development proposals should demonstrate that the space:

- is overlooked by surrounding development⁵;
- is accessible to wheelchair users and other disabled people;
- is designed to take advantage of direct sunlight⁶;
- has suitable management arrangements in place⁷.

2.0

Housing for a Diverse City

The best areas of London are places where people young and old, from different backgrounds and with different economic means and physical abilities can live side by side. This guide aims to ensure that every area of London accommodates the diversity of the city's population, and encourages new development to consider not just the initial occupiers of a home, but possible future tenants and owners. One of the key challenges of housing for Londoners

is to ensure that dwellings for smaller households will cater for people as they get partners, have children and grow older.

London has a great diversity of urban and suburban contexts, and we need to ensure that all new housing is built at a sustainable density, appropriate to its location. We also need to ensure that new development accommodates the other uses and activities that support daily life.

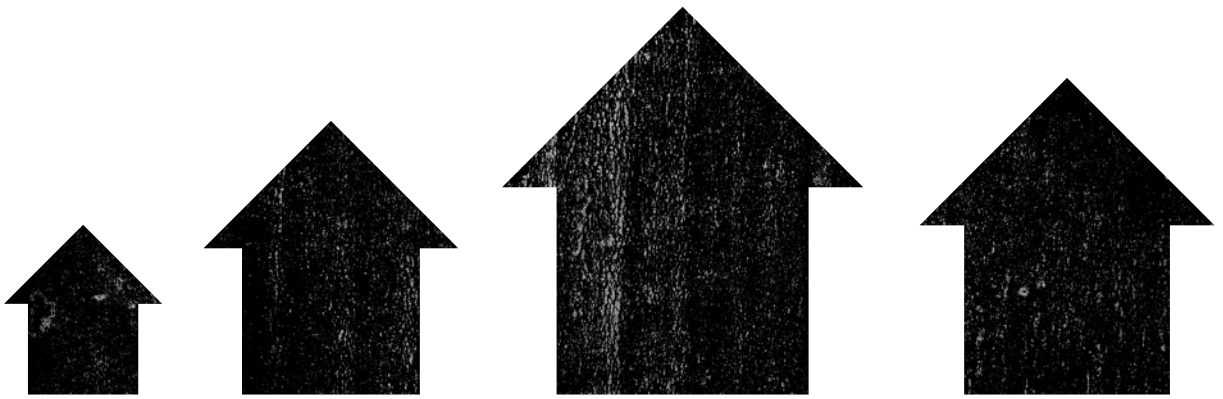



2.1 Appropriate Density

We need to develop housing to appropriate densities across the city to make the best use of land and public transport. In balancing priorities, it is crucial that boroughs take the lead in implementing London Plan policy. The London Plan defines the need to make optimum use of sites in areas with good public transport and community facilities, and to use moderation in areas where services and transport are scarce. We must avoid the problems that occur when large populations are concentrated in inaccessible places without the necessary facilities. While the density matrix in the London Plan provides the framework for optimising housing potential, the policy also stresses the importance of taking into account local context, the Plan's design principles and public transport capacity.

The density matrix of the London Plan outlines a range of density bands (described in habitable rooms and dwellings per hectare) in relation to public transport accessibility level (PTAL) and to the urban, suburban or central context of a location. PTAL maps for each borough, produced by Transport for London, may be used to assess the density range that is suitable for a particular development. For major applications referred to the Mayor, individual, site specific PTAL calculations are necessary.

When a housing type is developed to the upper limit of its possible density range, the result can be a loss of privacy and amenity space. Certain types of low-rise housing such as terraced or semi-detached housing with parking at grade only work well within a particular density range. The

relationship between density and housing type should be carefully considered in the early stages of design development.

Standards

2.1.1

Development proposals should demonstrate how the density of residential accommodation satisfies London Plan policy relating to public transport accessibility level (PTAL) and the accessibility of local amenities and services, and is appropriate to the location in London⁸.

London Plan Density Matrix (habitable rooms and dwellings per hectare):

Setting	Public Transport Accessibility Level (PTAL)		
	0 to 1	2 to 3	4 to 6
Suburban	150–200 hr/ha	150–250 hr/ha	200–350 hr/ha
3.8–4.6 hr/unit	35–55 u/ha	35–65 u/ha	45–90 u/ha
3.1–3.7 hr/unit	40–65 u/ha	40–80 u/ha	55–115 u/ha
2.7–3.0 hr/unit	50–75 u/ha	50–95 u/ha	70–130 u/ha
Urban	150–250 hr/ha	200–450 hr/ha	200–700 hr/ha
3.8–4.6 hr/unit	35–65 u/ha	45–120 u/ha	45–185 u/ha
3.1–3.7 hr/unit	40–80 u/ha	55–145 u/ha	55–225 u/ha
2.7–3.0 hr/unit	50–95 u/ha	70–170 u/ha	70–260 u/ha
Central	150–300 hr/ha	300–650 hr/ha	650–1100 hr/ha
3.8–4.6 hr/unit	35–80 u/ha	65–170 u/ha	140–290 u/ha
3.1–3.7 hr/unit	40–100 u/ha	80–210 u/ha	175–355 u/ha
2.7–3.0 hr/unit	50–110 u/ha	100–240 u/ha	215–405 u/ha

Appropriate density ranges are related to setting in terms of location, existing building form and massing, and the index of public transport accessibility (PTAL). The setting can be defined as:

- central – areas with very dense development, a mix of different uses, large building footprints and typically buildings of four to six storeys, located within 800 metres walking distance of an International, Metropolitan or Major town centre.
- urban – areas with predominantly dense development such as, for example, terraced houses, mansion blocks, a mix of different uses, medium building footprints and typically buildings of two to four storeys, located within 800 metres walking distance of a District centre or, along main arterial routes
- suburban – areas with predominantly lower density development such as, for example, detached and semi-detached houses, predominantly residential, small building footprints and typically buildings of two to three storeys.



2.2 Residential Mix

The London Plan seeks to ensure that residential developments provide an appropriate mix of housing types, sizes and tenures that can meet the full range of housing needs in neighbourhoods. It requires individual boroughs to specify, control and monitor the proportion and number of dwellings of each type provided in new developments.

Mix of Dwelling Sizes

Boroughs have an essential role to play in balancing the supply of housing for larger and smaller households and ensuring an adequate number of homes for larger families are provided, right across the city.

The last decade has been characterised by high-rise, high-density housing providing predominantly one- and two- bedroom flats often marketed towards young professionals. We cannot assume that people will follow a pattern of starting out in a flat, moving to a house when they have children and moving back into a smaller dwelling in old age. New housing needs to be designed with a range of people of different ages and backgrounds in mind who may occupy the home over its lifetime.

To make dwellings built for smaller households suitable for a wider range of people including families with children, we need to explore different models of housing. These will include maisonettes, a type that can deliver successful family housing at moderate densities. Where family flats are included in higher density development, developers must ensure that these provide at least some of the amenity afforded by houses, including private outdoor space.

Providing a mix of dwelling sizes has broad benefits in creating more balanced and sustainable communities⁹. Day to day, a good mix contributes to community safety, not least because some homes are more likely to be occupied throughout the day.

At the same time, real thought needs to be given to who will live in a new development and to the management issues that may result from the proposed mix of dwelling sizes. The extent to which housing for large families is mixed with one and two bedroom dwellings requires particular consideration.

Demographic evidence also points to the need for new housing which specifically meets the needs and aspirations of older people¹⁰. The supply of specialised housing, including wheelchair accessible and adaptable housing, has similarly failed to meet demand. Homes that are built for, or are easily adaptable to the needs of wheelchair users should be integrated into all development proposals, as required by the London Plan.

Mix of Tenure

A mix of tenure helps to address social exclusion. Communities with a mix of household incomes should be promoted across London, in small developments as well as larger schemes. A balanced mix of tenures should be sought, particularly in neighbourhoods where social renting predominates¹¹.

The design of buildings and spaces should be 'tenure blind' whereby homes for affordable rent, intermediate forms of tenure and private sale are indistinguishable from one another in terms of design quality, appearance or location within a site.

Different tenures should be integrated across the site as far as possible and large groups of any single tenure avoided. It is acknowledged, that complete ‘pepper-potting’, with mixed-tenure cores, often raises management issues and can have implications for resident service charges, particularly where lifts are involved. At the same time, we should consider that tenure often changes over the life of a dwelling. A key reason for the Mayor’s commitment to universal space standards is a desire to facilitate this fluidity.

Mix of Uses

Good neighbourhoods are about more than just good housing. The Mayor wants all new development to contribute to creating stronger neighbourhoods and lively places with a good range of services and amenities. People should be able to get to a station or bus stop, shop for food or relax in a park, café or pub within comfortable walking distance of their home. The best neighbourhoods are enjoyed by people of all ages, regardless of physical ability or financial means. These are places that people come to love for both the physical environment and the social relationships they encourage.

Proposals for larger residential developments should assess the need for community and ancillary services such as shops, local health and education facilities. The proximity and capacity of existing facilities will determine whether or not non-residential uses within development proposals are suitable.

Public and commercial uses at street level are therefore encouraged in appropriate

locations, where these uses are needed and can be supported. In situations where the future viability of non-residential uses is uncertain, it may be desirable to design ground floor dwellings to allow for conversion to other uses at a later date.

Combining different uses brings its own design challenges. Noise mitigation, deliveries, refuse collection, services, parking and access to homes and amenity space need even more careful design consideration in these circumstances, if the quality of home life is to be protected.

Where there are adjacent non-residential uses, care should be taken in the design of new residential development to avoid compromising the day to day functioning and long-term viability of those uses.

The management of buildings with multiple landlords should inform the design from the earliest stages and long-term management responsibilities should be defined in a joint management plan prior to Practical Completion.

Standards

2.2.1

Development proposals should demonstrate how the mix of dwelling sizes and the mix of tenures meet strategic and local borough targets and are appropriate to the location in London.

3.0

From Street to Front Door

The thresholds, front doors, common areas and walkways of a building can transform the perceived value of a home and help people feel proud of where they live. A central aim of this guide is to promote common areas that are well designed, welcoming and accessible to all, accompanied by management arrangements that are robust and viable in the long term. People value the design and management of interior and exterior shared spaces very highly, and arrangements well made can improve the safety and security of residents.

A driving concern for the design of groups of dwellings is to ensure that shared spaces outside and within buildings become places residents feel are intended for them. Many recent developments create spaces that are alienating in scale and lack this sense of ownership. A good example of this are apartment buildings with long, double-loaded corridors. These are more suited to a short-stay hotel and do little to foster a permanent sense of home. The Mayor is committed to encouraging alternatives to these patterns of housing.





3.1 Entrance and Approach

The design of the threshold between the public realm of the street and the private realm of the home affects people's sense of security in, and ownership of, their homes. Entrances should feel welcoming and offer shelter, and should be celebrated. It is especially important that individual homes in blocks of flats are given proper front doors and that the main entrances are of high quality.

For safety, entrances should be well lit and overlooked by the dwelling or by neighbouring properties. Entrances to communal cores or individual dwellings should be visible from the public realm, clearly identified and easy to find, with a direct line of approach from the street. The approach to all entrances, including the entrance closest to an accessible parking space, should be level or gently sloping. Where this is impractical, at least one entrance to a dwelling should meet this standard. All main entrances should be illuminated and should have level access over the threshold.

The clear opening width for communal entrance doors should be 800mm or 825mm depending on the direction and width of approach. A 300mm nib should be provided on the leading edge (pull side) of entrance and communal doors.

Paths from the street and from car parking should have a suitable width and gradient for wheelchair users, and there should be a level landing in front of any entrance door large enough for a 1500mm turning circle or a 1100 x 1400mm turning ellipse.

Further guidance on entrance areas of dwellings for wheelchair users may be found in Appendix 3.

Standards

3.1.1

All main entrances to houses, ground floor flats and communal entrance lobbies should be visible from the public realm and clearly identified¹².

3.1.2

The distance from the accessible car parking space of requirement 3.3.4 to the home or to the relevant block entrance or lift core should be kept to a minimum and should be level or gently

3.1.3

The approach to all entrances should preferably be level or gently sloping

3.1.4

All entrances should be illuminated and have level access over the threshold. Entrance doors should have 300mm of clear space to the pull side, and clear minimum opening widths of 800mm or 825mm depending on the direction and width of approach. Main entrances should have weather protection and a

3.2

Shared Circulation Within Buildings

Given the choice, many people, and most families, would prefer to live in a home with a private front door at ground level entered directly from the street or another public space. The challenge for higher density housing is to give some of the benefits of a private house (including privacy, security, a clear identity and private open space) to people living in apartments.

There are various forms of housing, including narrow frontage terraced housing, stacked maisonettes and flats with private access, which can achieve relatively high densities of up to 80 dph while providing a private front door at ground level. Above this density, it becomes necessary to arrange dwellings around vertical circulation within buildings.

With good design, control of numbers, and careful balancing of dwelling types, all forms of shared circulation can result in successful housing. But the choice should be a measured one. How dwellings are grouped has far-reaching implications for the social dynamics of a building, the maintenance and security arrangements, and the privacy, comfort and satisfaction of residents.

Housing based on double-loaded corridors has particular limitations both in the single-aspect dwellings they demand and in the circulation spaces, which are often poorly lit and ventilated. Apartment buildings with double-loaded corridors also have a damaging effect on the urban environment. The need for apartment blocks to face in two directions means that it is difficult to make a clear distinction between the front and back of a building. As a consequence of this it is challenging

to make a meaningful distinction between public and private, and this often leads to a lack of a clear sense of ownership over the spaces around the building. Tall buildings can also create large open spaces around their bases that are unanimated and do not foster a sense of ownership unless other uses are integrated into a podium or ground floor level.

With good design, other forms of shared circulation in apartment buildings can result in positive benefits for the amenity, privacy and quality of space within dwellings. For example, deck access can mean dwellings can be designed as dual aspect, potentially with a secondary outdoor amenity space.

The Number of People and Dwellings Sharing a Core and a Landing

Both the number of people and the number of dwellings sharing each access core will affect how intensively the space will be used. The safe maximum in terms of dwellings per core is generally considered to be 25. However, a core with 25 one bedroom flats (which will be occupied by up to 50 adults) will be of less concern than a core with 15 three-bedroom flats (with a maximum occupancy of 75 people, including almost 50 children). The likelihood of more visitors compounds the problem.

The mix of dwelling sizes and the number of dwellings in each core should therefore be carefully controlled. Tenure also affects the intensity of use because affordable rented dwellings are the most likely to be fully occupied.

In terms of the number of homes per floor, groups of 2-8 dwellings are usually desirable.

» Shared Circulation Within Buildings *continued*

In these smaller groups, residents tend to enjoy a greater sense of privacy, security and ownership and may be more likely to take an active interest in the upkeep of shared spaces. External circulation spaces shared by a limited number of people can also become places where residents can sit outside and socialise with neighbours. Management and maintenance is also easier with fewer users.

The Design of Shared Circulation

Shared circulation spaces need to be robust and convenient to use. Natural light, ventilation and views out are highly desirable, and the quality and durability of materials and fixtures should be as high as possible, especially door entry systems, floor finishes and lighting.

The principal access stairs in shared circulation cores should provide easy going stairs that have uniform risers not exceeding 170mm and uniform goings not less than 250mm with suitable handrails (see standard 3.2.8).

Lifts, stairs and dwellings should be easy to find and navigate by all users, including disabled and older people. Escape routes should be obvious from all areas of shared circulation and from every private dwelling entrance.

Shared entrances should open into a lobby or hall large enough for people to manoeuvre with shopping and baby buggies, and for wheelchair users to move with ease. Lobbies in larger developments will be multi-functional spaces, often needing to accommodate post and deliveries, storage for cycles, buggies and/or mobility scooters, as well as a concierge

desk, where appropriate. A cleaner's store or caretaker facility will often be required.

Shared corridors and staircases should be efficiently planned but wide enough for people to pass each other comfortably. This implies making all communal paths, corridors and decks a minimum width of 1200mm. A width of at least 1500mm is preferable, and is a particularly important consideration wherever user numbers are high, corridors are double-loaded or where wheelchair accessible dwellings are present.

Access Controls

All controls should be mounted at a height which is accessible to children and wheelchair users and keypads should include tactile numbers to help those with visual impairment.

A shared circulation core serving four or more dwellings should provide intercom control in every dwelling linked to the main front door for electronic lock release. As numbers increase, unless a concierge is provided, additional security measures including audio-visual verification to the access control system should be included.

Where a concierge service is provided, it is recognised that the number of dwellings served by a core may be safely increased, provided that the concierge is full time and the building has CCTV monitoring.

Standards

3.2.1

The number of dwellings accessed from a single core should not exceed eight per floor¹³.

3.2.2

An access core serving four or more dwellings should provide an access control system with entry phones in all dwellings linked to a main front door with electronic lock release¹⁴. Unless a 24 hour concierge is provided, additional security measures including audio-visual verification to the access control system should be provided where any of the following apply;

- **more than 25 dwellings are served by one core**
- **the potential occupancy of the dwellings served by one core exceeds 100 bed spaces**
- **more than 8 dwellings are provided per floor.**

3.2.3

Where dwellings are accessed via an internal corridor, the corridor should receive natural light and adequate ventilation.

3.2.4

The minimum width of all paths, corridors and decks for communal circulation is 1200mm. The preferred minimum width is 1500mm, and is considered particularly important where corridors are double loaded (serve dwellings on each side) and where wheelchair accessible dwellings are provided.

Lift Provision

Lifts make a range of daily tasks more manageable for everyone living in flats and are particularly important for older people and families with young children. They are essential for wheelchair users and other disabled people. Providing a lift and stairs at every core allows maximum choice and accessibility.

As a rule, at least one lift per core should be provided in all blocks of flats where any dwellings are entered on or above the fourth floor (fifth storey), measured from the main entrance level. Lift provision at the third floor (fourth storey) is desirable, as is the need to ensure that a significant proportion of family dwellings in any development have access to a lift. Where lifts are provided and storage, car parking or other facilities are located at basement level, lift access should serve these areas.

To provide cover in the event of breakdown, at least two lifts per core are required for any dwellings on or above the seventh floor (eighth storey) measured from the main entrance level, irrespective of the number of dwellings served. These requirements respond to the fact that it is generally considered unacceptable for people to have to walk up more than three flights of stairs on a daily basis, and unacceptable to have to walk up more than six flights even on an occasional basis.

All lifts must conform to Lifetime Homes Criterion 6 which requires a minimum internal car size of 1100mm x 1400mm (referred to as an eight-person lift) which can accommodate a wheelchair user with a companion. A lift of 2m by 1.4m (a 16

» Shared Circulation Within Buildings *continued*

person lift) allows a wheelchair user to turn around inside the lift¹⁵. Landings on each floor need to provide a clear space of at least 1500mm x 1500mm square. Lifts designed for ten or more people (1300mm x 1400mm and larger) facilitate the movement of bulky furniture, bicycles, stretchers and coffins. They are desirable in general, and a particularly important consideration for dwellings on or above the seventh floor.

Where family housing is provided in blocks of flats without lifts, developers should bear in mind that residents are likely to want additional secure storage space on the ground floor adjacent to the access stair for prams and other items.

Notwithstanding the desirability of lift access, and the fact that, in relative terms, the capital and maintenance costs of lifts are reducing all the time, they remain a major contributor to the service charges passed on to residents. A real tension therefore exists between the desire to restrict the number residents per core to a manageable level and the need to provide enough households to make lift service charges affordable. Designers and developers are asked to balance these issues carefully.

In cores where a lift is not provided from the outset, it is good practice to ensure that the design provides the space and servicing to allow for a lift to be installed in the future, either inside or outside of the building, adjacent to the landings. It is acknowledged that flexibility will be required in blocks with fewer than 15 dwellings where the cost of providing a lift would make viability unlikely, even in the future.

Standards

3.2.5

For buildings with dwellings entered from communal circulation at the first, second or third floor where lifts are not provided, space should be identified within or adjacent to the circulation cores for the future installation of a wheelchair accessible lift.

3.2.6

All dwellings entered at the fourth floor (fifth storey) and above should be served by at least one wheelchair accessible lift, and it is desirable that dwellings entered at the third floor (fourth storey) are served by at least one such lift. All dwellings entered at the seventh floor (eighth storey) and above should be served by at least two lifts.

3.2.7

Every designated wheelchair accessible dwelling above the ground floor should be served by at least one wheelchair-accessible lift. It is desirable that every wheelchair-accessible dwelling is served by at least two such lifts.

3.2.8

Principal access stairs should provide easy access¹⁶ regardless of whether a lift is provided. Where homes are reached by a lift, it should be fully wheelchair

3.3

Car Parking

Choosing how to accommodate parking – on the dwelling plot, on-site, on the street, in a parking court, undercroft or underground car-park – is a key decision that can have a major impact on the appearance and amenity of a development.

Well designed on-street and undercroft parking should be considered in preference to surface parking, in order to provide the maximum of amenity space and private gardens at ground level.

All forms of parking should be carefully integrated with the design of landscape and buildings, to reconcile residents' desire for convenient access to parking with the desire for pleasant streets and open spaces that are not dominated by cars.

Where on-plot parking is provided, spaces adjacent to the home should be capable of being widened to 3300mm to allow for wheelchair use, in accordance with Lifetime Homes.

The amount of on-site car parking provided should conform to London Plan policy on maximum parking provision and should relate to the public transport accessibility (PTAL level) of the site. In areas of good public transport accessibility and/or in town centres the aim should be to provide less than one space per dwelling. Elsewhere parking provision is related to the number of bedrooms in a new home.

The levels provided by the PTAL index are relatively general and the amount and type of on-site parking on a particular site should be agreed on an individual basis with the local borough, informed by an understanding of existing provision in the

area. Low on-site provision sometimes increases pressure on existing streets and can create resistance to development proposals.

Where on-site parking is provided in communal bays, one parking space of 3300mm should be provided adjacent to each communal entrance or lift core, in accordance with Lifetime Homes Standard 1.

Even where car-free developments are considered acceptable, developments should allow space for drop-off, emergency access, deliveries, maintenance, car clubs and meet the needs of disabled residents and visitors. In all developments providing dedicated wheelchair accessible dwellings, each of these dwellings should be allocated a designated wheelchair parking space in a convenient location. These parking bays need to be 1200mm wider than standard bays, so that a driver or passenger, either or both of whom may be disabled, can get in and out safely and easily. Extra length is also desirable to help with accessing luggage or a wheelchair in the car boot. Blue badge¹⁷ parking bays for blocks of flats should be located next to lift cores to minimise travel distances, and a drop-off point with level access should be provided close to all shared entrances. The parking management plan should include a mechanism to ensure that the supply of blue badge bays is regularly monitored and provision is reviewed against changing demand.

On-street parking is the cheapest and most flexible arrangement but without designation or permits, can only operate on a 'first come, first served' basis. Surface parking at the level of 1.5 spaces/dwelling

» Car Parking *continued*

is only likely to be achievable to a density of around 50dph, 1.0 space/dwelling to 70dph and 0.5 space/dwelling to 150 dph¹⁸. At higher densities than this it is likely that undercroft or underground parking will be necessary unless car-stacking or remote arrangements are made. These forms of parking carry with them hefty management, security and affordability implications and should not be undertaken lightly.

To promote the use of electric cars, electric charge points should be routinely included in new developments.

Standards

3.3.1

All developments should conform to London Plan policy on car parking provision¹⁹. In areas of good public transport accessibility and/or town centres the aim should be to provide less than one space per dwelling. Elsewhere parking provision should be as follows:

- 4+ bedroom dwellings: 1.5 - 2 spaces per dwelling;
- 3 bedroom dwellings: 1 - 1.5 spaces per dwelling;
- 1 - 2 bedroom dwellings: less than 1 per dwelling.

3.3.2

Each designated wheelchair accessible dwelling should have a car parking space 2400mm wide with a clear access way to one side of 1200mm. Refer to appendix 3 for design standards for wheelchair accessible housing.

3.3.3

Careful consideration should be given to the siting and organisation of car parking within an overall design for open space so that car parking does not negatively affect the use and appearance of open spaces²⁰.

3.3.4

Where car parking is within the dwelling plot, at least one car parking space should be capable of enlargement to a width of 3300mm. Where parking is provided in communal bays, at least one space with a width of 3300mm should be provided per block entrance or access core in addition to spaces designated

3.4 Cycle Storage

In the past, far too little space has been provided for cycle storage in new developments. The Mayor wishes to increase the provision of secure, convenient and sheltered cycle storage for new homes in London, to encourage people to use bicycles for everyday journeys.

Cycle storage, which may be outside or within the home, should be provided at the level of one space for every home with one or two bedrooms and two spaces for homes with three or more bedrooms. The requirement is the same for houses and flats. Floor-space of 750 x 2000mm is a suitable guideline area per bicycle, but vertical hanging and lockers will have different space requirements. The location, type and number of cycle storage spaces should be indicated and dimensioned on plans submitted for full planning approval.

Cycle storage outside the home should be located in a convenient and easily accessible storeroom, private garden or secure common space close to the street. Wherever possible, large communal stores and out of the way locations and should be avoided, as they tend to be vulnerable to cycle theft. The preferred option for residents is usually an individual lockable compartment, close to home.

Where cycle storage is provided within the dwelling, the space must be in addition to the minimum GIA, and located at entrance level, within, or adjacent to the circulation area, rather than within habitable rooms or on balconies.

Developments should also provide cycle parking provision for visitors; secure hoops

or stands are usually the most convenient for short stay use. Cycle stands should be located away from main pedestrian desire lines to avoid creating obstruction.

Standards

3.4.1

All developments should provide dedicated storage space for cycles at the following levels²¹:

- 1 per 1 or 2 bedroom dwelling; or
- 2 per 3 or more bedroom dwelling

3.4.2

Individual or communal cycle storage outside the home should be secure, sheltered and adequately lit, with convenient access to the street²².

Where cycle storage is provided within the home, it should be provided in addition to the minimum GIA and minimum storage and circulation space requirements. Cycle storage identified in habitable rooms or on balconies will not be considered acceptable.



3.5 Refuse, Post and Deliveries

The London Plan requires suitable storage facilities for waste and recycling in all new developments²³. This guide requires developers to achieve full credits under the Code for Sustainable Homes for the storage of non-recyclable and recyclable household waste. Designers should refer to the Code Technical Guide (WAS 1) for detailed information on the assessment methodology.

Waste and recycling is a rapidly changing field and there remain significant variations in local authority policy which need to be reconciled with the requirements of the Code for Sustainable Homes guidance. Designers are encouraged to consult early with local waste management officers about capacity, location and collection methods and frequency. It is wise to build in some flexibility and anticipate ever-increasing levels of recycling.

The type of storage should be carefully considered in relation to the nature of the scheme and road layout, as well as local policy. Ground level communal refuse and recycling stores often have a negative visual impact on the streetscape and are noisy and smelly. Locations close, but not adjacent to shared entrances are usually best when bagged waste is carried down and deposited by residents.

Within buildings, refuse chutes and stores also need to be designed and located to limit the nuisance caused by noise and smells. Dwellings next to, or above, refuse stores will need special design consideration in terms of the placement of habitable rooms, windows, balconies and vents in order to preserve amenity.

All refuse and recycling containers, communal bin enclosures and stores should be accessible to people of all ages and to wheelchair users, and located on a hard, level surface. All storage areas should be provided with facilities for washing and cleaning.

In high-density developments, a caretaker service to help with waste management may be appropriate and compactors should be considered. Underground storage relies on the local authority having the right lifting equipment and requires mechanical ventilation. Automated waste collection systems also have special collection requirements and require careful design. The energy use of these systems should be weighed up against their potential benefits.

Many boroughs now collect food waste (cooked food and table scraps) and organic waste for composting (grass clippings and raw fruit and vegetable peelings). Composting organic waste on site is another important and often overlooked method of reducing waste which brings positive benefits to residents. A central composting point is desirable in all new developments. To avoid confusion with collected food waste, a composting area should be separate from the refuse storage and connected to an amenity space.

Post and Deliveries

In dwellings at street level, mailboxes in individual front doors are preferable. For upper floor flats, mailboxes should usually be banked either on the external wall close to the entrance, to allow delivery from outside and collection from

inside the lobby, or within the lobby, monitored by the concierge, where present. Individual mailboxes should be secure, robust, large enough for A4+ sized envelopes and magazines, and accessible to people of all ages and wheelchair users. Freestanding banks of postboxes outside the entrance to a development should be avoided, as they are less secure and may encourage vandalism.

Estimates suggest that internet shopping will account for half of all retail sales by 2020 and that half of these sales will require home deliveries²⁴. This has design implications for access and delivery as well as a need to make secure arrangements for receipt and short-term storage when people are not at home. Where a concierge is not present, lockable delivery boxes should be considered.

Standards

3.5.1

Communal refuse and recycling containers, communal bin enclosures and refuse stores should be accessible to all residents including children and wheelchair users, and located on a hard, level surface. The location should satisfy local requirements for waste collection and should achieve full credits under the Code for Sustainable Homes, in accordance with the Technical Guide²⁵. Refuse stores within buildings should be located to limit the nuisance caused by noise and smells and provided with means for cleaning.

3.5.2

Storage facilities for waste and recycling containers should be provided in accordance with the Code for Sustainable Homes Technical Guide and local authority requirements.

4.0

Dwelling Space Standards

No amount of sensitive design can compensate for houses and flats that are too small. The new minimum space standards at the heart of this guidance will improve residents' quality of life and ensure that our homes are accessible and able to accommodate changing personal circumstances and growing families.

Extra space will enable homes to be more than mere dormitories, encouraging sociable rooms within homes, and giving

individual family members private space when they need it.

This section sets out essential minimum standards for the gross internal floor area (GIA) and private outdoor space of general needs housing, and it provides guidance on the size and layout of rooms and storage areas. This guidance aims to make more generous housing that can allow people to live a full life in the city.

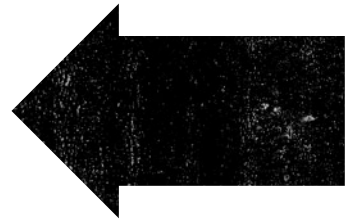
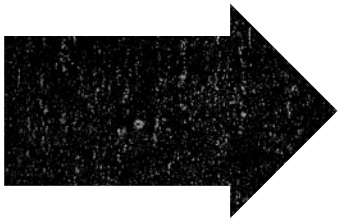



4.1 Internal Floor Area

In our homes we need sociable rooms in which we can gather with friends and family, and private spaces in which we can enjoy being alone. Play, work and study are as much a part of daily life as cooking, eating and sleeping, while storage and circulation areas support, and provide essential buffers between, these varied and conflicting activities.

By defining overall space standards for a range of occupancy levels and breaking these down into suggested standards for individual rooms, this guide aims to ensure that new homes will meet these needs in the long term.

Minimum gross internal areas (GIA) for new homes are based on the number of storeys in a dwelling and the number of occupants the dwelling is designed to accommodate²⁶. The study forming the basis of the space standards is summarised in appendix 1.

It is important to remember that these minimum space standards should not be taken as maximum areas. Housing which exceeds minimum dwelling sizes will always be encouraged, and in order to achieve certain design configurations or work within site constraints, designers and developers may need to make early allowance to exceed the minimum GIA.

Although it is best practice to meet the desirable standards for room areas and dimensions, where these standards cannot be met the priority should be to accommodate the furniture and activity space required for the intended number of occupants (see appendix 2) while not falling

below the minimum GIA. The schedule in appendix 2 represents a reasonable provision to meet day-to-day needs.

Additional rooms, including utility rooms, studies and en-suite bathrooms, are encouraged, but will require additional floor area above the minimum GIA to avoid compromising the space and functionality of other parts of the home.

Space Standards and Occupancy

The new mandatory minimum space standards are intended to ensure that all new homes in London are fit for purpose and offer the potential to be occupied over time by households of all tenures. The minimum gross internal floor area (GIA) required for any given dwelling type relates to the following variables:

- the number of people for whom the home has been designed (equivalent to the number of bedspaces it provides - typically 2-8)
- the number of bedrooms it provides (typically 1-5)
- the number of storeys it contains (typically 1-3)

The minimum GIAs for the most commonly used dwelling types are set out in table 4.1.1. These areas allow for the minimum habitable room areas, the amount of circulation and storage space, and the number of bathrooms and WCs which are considered desirable for each dwelling type, based on its potential occupancy.

In principle, the minimum amount of space needed per person is not felt to vary by tenure, though it is accepted that levels of occupancy do tend to be tenure related.

26. See Appendix 4 for guidance on measuring gross internal area

In practice, homes for affordable rent are more likely to be fully occupied than those which are owner occupied. However, to ensure that all future homes will be comfortable when occupied to their full potential under any tenure, four simple principles apply:

- each home for two or more people should contain at least one double/twin bedroom
- each single bedroom should provide one adequate bed space (a floor area of 8 sq m is considered the desirable minimum)
- each double/twin room should provide two adequate bedspaces (a floor area of 12 sq m is considered the desirable minimum)
- all bed spaces should be counted when declaring the potential occupancy level of the dwelling

Choice, flexibility and market preferences are actively encouraged by the following:

- 1 bedroom homes are considered suitable for 1-2 people
- 2 bedroom homes are considered suitable for 3-4 people
- 3 bedroom homes are considered suitable for 4-6 people
- 4 bedroom homes are considered suitable for 5-8 people
- 5 bedroom homes are considered suitable for 6-10 people

Notwithstanding the flexibility facilitated by this broad mix, London has seen too many new homes built at, or even below, the lower end of each range of potential occupancy. Many new one bedroom homes only provide enough space for one person and many of those with three bedrooms can only be considered

suitable for full time occupancy by two or three people. This is particularly evident in the private sector, where, for example, relatively few three bedroom flats achieve a GIA of 86 sq m – the minimum considered adequate for a family of five.

To ensure that shortfalls are addressed, choice is widened and local demand is reasonably met, individual boroughs will be encouraged to define the mix of dwellings required for a proposed development – and to do so by occupancy, rather than by the number of bedrooms.

So for example, where there is high demand for five person homes, this will mean that some flats with three bedrooms will be required to have a GIA of at least 86 sq m. Some smaller three bed flats, with a GIA between 74 sq m and 86 sq m, are likely to be acceptable in principle (subject to providing a good distribution of internal space, including enough storage) as good homes for four people of any tenure. In line with other recommendations in this chapter, local planners may also seek to restrict or encourage specific dwelling types, for example it may be desirable to restrict 2b4p, 3b6p and 4b8p dwelling types, particularly in affordable housing, because these types prevent any child from having a bedroom to themselves when the dwelling is fully occupied.

The draft Housing SPG provides the flexibility for developers to propose a proportion of single person dwellings of less than 50 sq m in central areas, where there is very good public transport accessibility (PTAL) and access to local services and amenities, subject to

» **internal Floor Area** *continued*

local authority quotas and restrictions on dwelling numbers. Based on the space standards study (appendix 1), the recommended minimum area of a one person, one bedroom dwelling is 37 sq m where the dwelling has a shower room, and 39 sq m where the dwelling has a bathroom. Single person dwellings will be required to meet the Lifetime Homes standards.

Great care needs to be taken to prevent high concentrations of this type of dwelling. Single person dwellings should never be allowed to become a dominant part of the mix within a local urban context.

Reviewing Designs at Planning Application Stage

At planning application stage, developers are encouraged provide the following information for each dwelling or dwelling type:

- Dwelling plans not smaller than 1:100 scale with metric room dimensions showing the position of furniture and activity zones scheduled in appendix 2 and spaces allocated for a washing machine, for drying clothes, and for storing waste and recycling bins within the home (see section 4.7).
- the maximum potential occupancy
- the GIA
- the combined area of the kitchen, dining space and living space
- the area of each bedroom
- the area of dedicated built-in storage free of services and appliances and at least 2m high internally
- the area and dimensions of private outdoor space

Standards

4.1.1

All developments should meet the following minimum space standards.

	Dwelling type (bedroom/ persons)	Essential GIA (sq.m)
Single storey dwelling	1b2p	50
	2b3p	61
	2b4p	70
	3b4p	74
	3b5p	86
	3b6p	95
	4b5p	90
	4b6p	99
Two storey dwelling	2b4p	83
	3b4p	87
	3b5p	96
	4b5p	100
	4b6p	107
Three storey dwelling	3b5p	102
	4b5p	106
	4b6p	113

For dwellings designed for more than 6 people, at least 10 sq m gross internal area should be added for each additional person.

4.1.2

Dwelling plans should demonstrate that dwellings accommodate the furniture, access and activity space requirements relating to the declared level of occupancy. Refer to appendix 3 for design standards for wheelchair accessible housing.

4.2

Flexibility and Adaptability

People do not always want, nor are they always able, to move home as their circumstances change. Every home should be flexible enough to accommodate a range of possible changes in circumstances. This is one of the key principles of the new minimum space standards and the Lifetime Homes standards. Flexibility in housing is the basis of the longevity of the best parts of our city.

Flexibility is the potential for rooms in a home to be used in a variety of ways without altering the building fabric. In practice, this means making individual rooms large enough to accommodate different types and arrangements of furniture, carefully considering the location of doors, windows and built-in furniture, and building in the potential for spaces to be linked or separated without moving walls or changing the position of openings.

At planning application stage, designers are encouraged to indicate on the submitted plans how dwelling types facilitate flexible use. This can be achieved by showing that alternative seating arrangements can be accommodated in the main living space, or that double bedrooms can accommodate double or twin beds.

Homes in which living, dining and kitchen functions are combined in a single space make it difficult for family members to pursue different activities at the same time without disturbing each other (see section 4.4). Even very large rooms will not be flexible when there is an insufficient area of external wall with windows to allow for sub-division.

Adaptable homes go further by offering the potential for internal spaces to be modified with relative ease. Thoughtful design can facilitate adaptation by positioning structural supports to allow new openings in internal walls, or by creating easily demountable partitions which are clear of services²⁷.

Standards

4.2.1

Dwelling plans should demonstrate that dwelling types provide flexibility by allowing for an alternative seating arrangement in living rooms and by accommodating double or twin beds in at least one double bedroom.



4.3 Circulation in the Home

All parts of the home should be designed for ease of access according to Lifetime Homes principles and hallways should be wider in larger family homes, where they are used more intensively.

Inside the dwelling entrance there should be space to offload and store outdoor items (such as prams, umbrellas, coats and boots) without the need to pass through habitable rooms.

Natural light significantly improves the quality of circulation areas. These spaces can also provide a thermal buffer between outdoors and the habitable rooms of a dwelling, and can help with regulating temperatures and passive solar heating.

Under Lifetime Homes, the minimum widths of doorways and hallways are determined by the relationship between the door opening width, the hallway width and the direction of entry. Together, these dictate the ease with which a wheelchair user can turn into a space; allowing them to visit friends and family in homes that are not suitable for a wheelchair user to occupy on a full-time basis. (see Standard 4.3.1).

To anticipate the changing needs of occupants, the design of dwellings over more than one storey should permit the installation of a stair lift and a wheelchair-accessible through-the-floor lift. The potential route for a through-the-floor lift may be from a living room to a bedroom above, or from, or arriving in, a circulation area. An aperture or soft spot of 1000 x 1500mm is needed for a through-the-floor lift in concrete and other solid floors. A potential space for the aperture should

be identified in timber joisted floors. This should be clear of services and with a potential approach from one of the shorter sides. In certain circumstances, provision for a future stair lift alone may satisfy the standard.

Standards

4.3.1

The minimum width of hallways and other circulation spaces inside the home should be 900mm. This may reduce to 750mm at 'pinch points' e.g. next to radiators, where doorway widths meet the following specification:

Minimum clear opening width of doorway (mm)	Minimum approach width when approach is not head on (mm)
750	1200
775	1050
900	900

Where a hallway is at least 900mm wide and the approach to the door is head-on, a minimum clear opening door width

4.3.2

The design of dwellings of more than one storey should incorporate potential for a stair lift to be installed and a suitable identified space for a through-the-floor lift from the entrance level²⁸ to a storey containing a main bedroom and

4.4 Living, Dining and Kitchen Areas

29. Accommodating Diversity: Housing Design in a Multicultural Society, National Housing Federation, 1998

The combined area of the living room, dining room and kitchen is an important measure of the quality of space within a home. The minimum combined living areas in this guide allow the designer the freedom to organise and combine these spaces in different ways while safeguarding the overall living space within a dwelling.

An open-plan layout of living, dining and kitchen spaces is often considered to be the market preference, but there are times when it is preferable to achieve a degree of separation, at least between the living space and the work area of the kitchen.

Homes for larger families must cater for activities involving any number of members of the family, with or without guests. Dwellings with three or more bedrooms should have two social spaces, for example a living room and a kitchen-dining room – both with external windows.

Where housing is being designed for specific cultural needs, designers might find a preference for the kitchen to be separated from the living and dining spaces. Different methods of cooking may demand larger kitchens with better ventilation²⁹.

Narrow living rooms are not usually useful, enjoyable or flexible. To allow sufficient space for circulation around furniture, and allow people to sit or play as a group, the guide recommends that the width of the principal sitting space is at least 3.2m for dwellings with four or more occupants, and at least 2.8m in dwellings for those with fewer than four occupants.

There should be space to turn a wheelchair in dining areas and living rooms and there should be basic circulation space for wheelchair users elsewhere. The provision of a 1500mm turning circle or 1400 x 1700mm ellipse in living and dining areas connected by a wheelchair accessible route to the front door will satisfy this standard.

A living room, living space or kitchen-dining room should be at entrance level²⁸, to provide accessible social space for visitors unable to use stairs.

To allow people to see out of living room windows while seated, the base of principal window glazing should be a maximum of 800mm – 850mm above the floor.

Standards

4.4.1

The following combined floor areas for living, kitchen and dining space should be met:

Designed occupancy	Minimum combined floor area of living, dining and kitchen spaces (sq m)
2 person	23
3 person	25
4 person	27
5 person	29
6 person	31

» Living/Dining/Kitchen *continued*

4.4.2

The minimum width of the main sitting area should be 2.8m in 2-3 person dwellings and 3.2m in dwellings designed for four or more people.

4.4.3

Dwellings with three or more bedrooms should have two living spaces, for example a living room and a kitchen-dining room. Both rooms should have external windows. If a kitchen is adjacent to the living room, the internal partition between the rooms should not be load-bearing, to allow for reconfiguration as an open plan arrangement. Studies will not be considered as second living spaces.

4.4.4

There should be space for turning a wheelchair in dining areas and living rooms and basic circulation space for

4.4.5

A living room, living space or kitchen-dining room should be at entrance level²⁸

4.4.6

Windows in the principal living space should start 800mm above finished floor level (+/- 50mm) to allow people to see out while seated. At least one opening window should be easy to approach and operate by people with restricted

4.5 Bedrooms

People often use bedrooms for work and study, or to relax away from the social spaces of the home. Children and young people need space in bedrooms for homework, play and hobbies, storing their belongings, entertaining friends, and spending time alone.

The preferred standards for the minimum floor areas of bedrooms are 8 sq m for single bedrooms and 12 sq m for double and twin bedrooms. These minimum areas have been established by considering the activity and furniture requirements of the Homes and Communities Agency's legacy HQI standards, set out in appendix 2, and the Lifetime Homes requirement for basic circulation space for wheelchair users within bedrooms.

Double and twin bedrooms have the same recommended minimum floor area to encourage designers to design rooms suitable for adults or children, with one double bed or two single beds. It will be important that the location of the door, window and any built-in furniture allows for this. Double and twin bedrooms should have a minimum width of 2.75m to allow sufficient space for a wheelchair user to pass the foot of the bed when the head is placed against the side wall.

In homes of two or more storeys there should be a convenient bed space at the entrance level²⁸ to help with a temporary change in circumstances (such as a household member recovering from a hip operation or a broken leg).

Dwellings should allow a convenient wheelchair route from a main bedroom to the bathroom and for the ceiling above the main bedroom and the bathroom to be capable of supporting a hoist.

Standards

4.5.1

The minimum area of a single bedroom should be 8 sq m. The minimum area of a double or twin bedroom should be 12 sq m.

4.5.2

The minimum width of double and twin bedrooms should be 2.75m in most of the length of the room.

4.5.3

In homes of two or more storeys with no permanent bedroom at entrance level²⁸, there should be space on the entrance level that could be used as a convenient

4.5.4

Structure above a main bedroom and an accessible bathroom should be capable of supporting a ceiling hoist and the design should allow for a reasonable route between this bedroom and



4.6 Bathrooms and WCs

The minimum GIAs provide sufficient space for one bathroom with WC in dwellings occupied by between two and four people, and one bathroom with WC and one additional WC in dwellings occupied by five or more people. Where developers want to create additional bathrooms, shower rooms or WCs the extra floorspace should be provided in addition to the minimum GIA.

A wheelchair-accessible WC and drainage for a potential shower should be provided at entrance level²⁸ in homes of more than one storey where there is no entrance level accessible bathroom, to provide an accessible WC to serve visitors unable to use stairs, or for a household member using a temporary entrance-level bed space. In one- and two-bedroom dwellings over more than one storey a Part M compliant WC and drainage for a potential shower at entrance level will satisfy the requirement.

The accessible bathroom provided in every dwelling should be on the same storey as one of the main bedrooms, and should not be en-suite (solely accessed from the bedroom) unless another accessible bathroom is also provided.

To satisfy Lifetime Homes Criterion 10 in respect of the entrance level accessible WC with shower drainage, the following recommendations should be incorporated:

- The centre line of the WC should be 400mm – 500mm from a side wall.
- The WC should have a flush handle located on the side away from the side wall or an easy to reach flush button.
- There should be a clear approach zone around the WC, extending at least

350mm from the centre-line of the WC on one side and at least 1000mm from the centre-line of the WC on the other side. This zone should extend in front of the WC by at least 1100mm and should extend back at least 500mm from the front edge of the WC for a width of 1000mm from the centre-line. A washbasin may be located either on the side wall or adjacent to the cistern, and should not project into the approach zone by more than 200mm.

- A clear 1100mm deep zone should be provided in front of any obstruction under the washbasin.
- Unless provided elsewhere on the entrance level, floor drainage for an accessible shower should be provided in the WC with either shallow falls in the floor to effect drainage, or a floor that allows for the easy installation of a laid-to-fall floor surface in the future.
- A clear floor area for showering of 1000mm x 1000mm should be provided.

To satisfy Lifetime Homes Criterion 14 in relation to accessible bathrooms, the following two additional points should be incorporated in addition to the five points above:

- A clear floor area for showering of 1000mm x 1000mm should be provided if a showering area is provided in addition to a bath.
- Where an accessible shower is provided from the outset with no bath, a clear 1500mm manoeuvring circle, or a clear 1400mm x 1700mm ellipse should be provided at floor level, overlapping with the showering zone.

30. Housing Quality Indicators Version 4, (former) Housing Corporation, 2007

31. Dwellings over more than one storey with no more than two bedrooms may instead be designed with a Part M compliant WC at entrance level. The WC should provide a floor drain to allow for an accessible shower to be installed at a later date.

32. Adequate support for grab rails should be available at any location on all walls within a height band of 300mm - 1800mm from the floor.

The diagrams in appendix 1 provide examples of bathrooms meeting the accessibility standards of Lifetime Homes.

Standards

4.6.1

Dwellings designed for an occupancy of five or more people should provide a minimum of one bathroom with WC and one additional WC³⁰.

4.6.2

Where there is no accessible bathroom at entrance level²⁸, a wheelchair accessible WC with potential for a shower to be installed should be provided at entrance

4.6.3

An accessible bathroom should be provided in every dwelling on the same

4.6.4

Walls in bathrooms and WCs should be capable of taking adaptations such as



4.7

Storage and Utility Spaces

The lack of storage is a major problem in new homes³³. Everyday household items including cleaning equipment need to be readily accessible. Other belongings are only in seasonal use or occasional use, (suitcases or decorating equipment for example) and things like baby equipment may need to be stored away for some time. Without adequate storage space, people's belongings will take space away from the rooms of the home and limit enjoyment of them.

This guide sets out essential minimum areas for dedicated built-in storage cupboards of 1.5 sq m for 2 person dwellings and 0.5 sq m for each additional occupant. Storage cupboards should be free of hot water cylinders, boilers, heat exchangers or washing machines and all parts of the cupboard should be a minimum of 2m high internally.

Developers are encouraged to provide additional secure storage cupboards for individual dwellings at ground or basement level in flatted developments, and external storage for outdoor equipment in dwellings with gardens.

People also need suitable spaces outside habitable rooms for waste and recycling bins, washing machines and for drying clothes. The Code for Sustainable Homes recommends that recycling bins are located in a dedicated non-obstructive position in a kitchen cupboard, in a utility room next to the kitchen or in a connected garage. Space for a washing machine is included in the furniture schedule for the kitchen but may alternatively be located in another suitable area such as the bathroom, or a utility room or laundry cupboard.

People also need suitable spaces outside habitable rooms for waste and recycling bins, washing machines and for drying clothes. The Code for Sustainable Homes recommends that recycling bins are located in a dedicated non-obstructive position in a kitchen cupboard, in a utility room next to the kitchen or in a connected garage. Space for a washing machine is included in the furniture schedule for the kitchen but may be located in another suitable area such as the bathroom, or a utility room or laundry cupboard. Drying clothes takes up space and gives off moisture which can contribute to condensation, so the internal space identified for clothes drying should not be within habitable rooms or the kitchen and should preferably be well ventilated and heated.

A dedicated utility room with space and services for a boiler, washing machine (and preferably heating and ventilation for drying clothes) will always be desirable in any size of home, and in family dwellings designed for five or more people, providing a utility room is recommended.

Standards

4.7.1

Built-in general internal storage space free of hot water cylinders and other obstructions, with a minimum internal height of 2m and a minimum area of 1.5 sq m should be provided for 2 person dwellings, in addition to storage provided by furniture in habitable rooms. For each additional occupant an additional 0.5 sq m of storage space is required.

4.8

Study and Work

Work and study are a regular part of home life for many people, across all age groups. Flexible working patterns and wider access to the internet are making it possible for more people to work from home.

Credits are awarded under the Code for Sustainable Homes for providing space and services that enable a room to be used effectively as a home office. Sufficient space is defined as the minimum area to allow a desk, chair and filing cabinet or bookshelf to be installed, with space to move around the furniture. A suitable room may be the living room (in dwellings with 1-2 bedrooms), one of the bedrooms or a large hall or dining area, where sufficient space, natural light and services are provided. When homes are not fully occupied, people may choose to convert bedrooms into studies or home offices.

In all rooms of the home, switches, sockets and other service controls should be positioned within an accessible height band of 450mm to 1200mm from the floor and at least 300mm away from any internal room corner.

Standards

4.8.1

Dwelling plans should demonstrate that all homes are provided with adequate space and services to be able to work from home. The Code for Sustainable Homes guidance on working from home is recommended as a reference³⁴.

4.8.2

Service controls should be within a height band of 450mm to 1200mm from the floor and at least 300mm away



4.9 Wheelchair User Dwellings

The London Plan seeks to address the current shortage of wheelchair accessible housing in London by requiring ten per cent of all new housing to be designed as wheelchair accessible or easily adaptable for wheelchair users. In this context, easily adaptable means the home will not require structural alterations to make it suitable for wheelchair users, but might require minor alterations such as installing grab rails, replacing a bath with a shower or changing the kitchen units.

The design of wheelchair user dwellings should reflect the principles of inclusive design. Wheelchair user dwellings should not look different from adjacent homes and they should be able to respond to individual needs and circumstances, to enable residents to participate in and be full members of the local community. They should be dispersed across the development, providing choice in aspect and floor level, and should be distributed across all tenures, with a mix of dwelling types to cater for a broad range of household sizes, ages of residents and varying family needs.

Careful planning and generous space standards can occasionally allow the adaptation of a Lifetime Home for use by some wheelchair users, but in schemes where homes are designed to the minimum space standards and where occupancy levels will remain the same, wheelchair user dwellings will need to be larger to provide accessible circulation, to allow convenient and dignified use of bathrooms, and to provide space for a variety of mobility equipment and adequate storage within reach in kitchens and bedrooms. Dwelling

plans for designated wheelchair accessible dwellings submitted with a planning application should demonstrate that the dwellings can be easily and conveniently occupied by a wheelchair user.

The key requirements for wheelchair user dwellings are set out in the GLA's Best Practice Guide on Wheelchair Accessible Housing³⁵, which is summarised in Appendix 3.

Standards

4.9.1

Ten percent of new housing should be designed to be wheelchair accessible or easily adaptable for residents who are wheelchair users in accordance with the GLA Best Practice Guidance, Wheelchair Accessible Housing. Refer to appendix 3 for design standards for wheelchair accessible housing.

4.10 Private Open Space

Private open space is desirable in all circumstances and, in general, the more private open space provided per home, the better. This guide requires that all dwellings should be provided with adequate private open space in the form of a garden, terrace, balcony or glazed wintergarden.

Private open space standards have been established in the same way as internal space standards, by considering the space required for furniture, access and activities and in relation to the number of occupants. A minimum of 5 sq m of private outdoor space is required for all 2 person dwellings and an extra 1 sq m should be provided for each additional occupant. The required minimum width and minimum depth for all balconies and other private external spaces is 1500mm. These minimum areas and dimensions provide sufficient space for either a meal around a small table, clothes drying, or for a family to sit outside with visitors.

Enclosing balconies as glazed, ventilated winter gardens is a good option in many circumstances and is recommended for all dwellings exposed to NEC noise category C or D³⁶, or strong wind, particularly at high level. Winter gardens should be thermally separated from the interior and the floor should be drained.

In exceptional circumstances, where site conditions make it impossible to provide private open space for all dwellings, up to 5% of dwellings in a development may instead be provided with additional internal living space equivalent to the private open space requirement, added to the minimum GIA and the minimum combined living area of the dwelling.

Under the Lifetime Homes standards, private open spaces should have level access from the home with an upstand not exceeding 15mm and a level, weather-tight threshold. Exemptions will be considered for inset balconies and roof terraces where a step up is necessary to accommodate thermal insulation to the accommodation below.

Balconies should be designed to provide some shelter and privacy from neighbouring properties. This can be achieved using screens or by setting the balcony back within the facade. Balconies should have solid floors draining to a downpipe. Where balconies overlook noise sources, solid parapets and absorbent soffit materials should be considered for their acoustic benefits.

Where possible, rear gardens should have separate direct access so that bicycles and garden equipment may be taken into the garden without passing through the home.

Private outdoor spaces will be used for drying clothes, and the area schedule in appendix 2 allows space for 4m of drying line for 1-2 bedroom dwellings and 6m for 3+ bedroom dwellings, which could be in the form of a clothes rack, rotary dryer or drying line.

Secured by Design principles should be incorporated in the design of all private outdoor spaces. For example, fences and balconies (as well as communal bins and cycle stores) should be designed so as not to provide climbing aids to gain access into a property³⁷.

Standards

4.10.1

A minimum of 5 sq m of private outdoor space should be provided for 1-2 person dwellings and an extra 1 sq m should be provided for each additional occupant³⁸.

4.10.2

Private outdoor spaces should have level

4.10.3

The minimum depth and width of all balconies and other private external spaces is 1500mm⁴⁰.

38. Based on the furniture, access and activity requirements of the HCA legacy Housing Quality Indicators Version 4, 2007, and drying space and private open space requirements of the Code for Sustainable Homes Technical Guide, 2009, ENE4 and HEA3 39. Balconies and terraces over habitable rooms which require a step up to increase slab thickness for insulation are exempt from the Lifetime Homes level access standard.

40. Based on the Quality Standards: Delivering Quality Places, (former) English Partnerships, 2007, the furniture, access and activity requirements of the HCA legacy Housing Quality Indicators Version 4, 2007, and drying space and private open space requirements of the Code for Sustainable Homes Technical Guide, 2009

5.0

Home as a Place of Retreat

Surrounded by the noise and activity of daily life in London, it can be difficult to make homes that offer people a place to withdraw and retreat from the city. Even in the suburbs, traffic noise and adjacent uses can be hostile to the quiet repose we want from our homes.

To address this, the guidance in this section proposes standards around privacy and noise mitigation, but also recognises the importance of generous ceiling heights and natural light to the sense of wellbeing we take from our homes. We are determined to encourage the kind of housing that provides comfortable and enjoyable places of retreat and privacy.

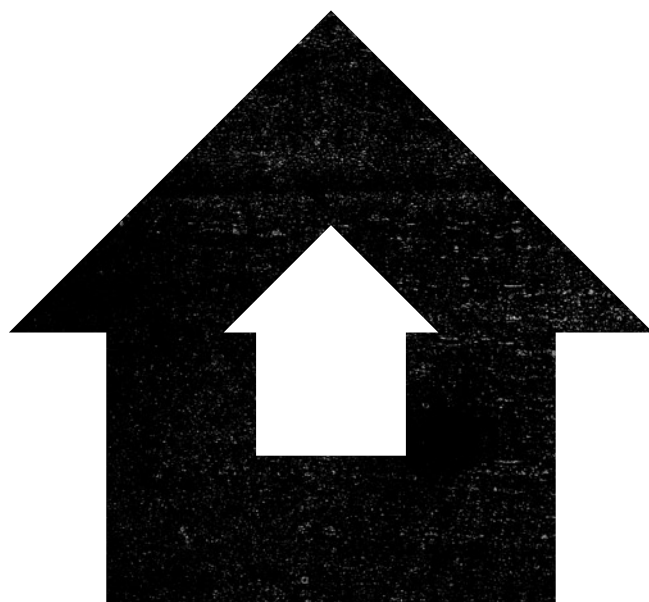



5.1 Privacy

Homes in the city should provide the opportunity to look out on and enjoy surrounding public and shared open spaces. At the same time, the home should be a comfortable, private setting for family and individual pursuits, social interaction and relaxation. Private outdoor space should also offer these qualities. People value highly the opportunity to relax outdoors without being seen by neighbours or passersby.

In the past, planning guidance for privacy has been concerned with achieving visual separation between dwellings by setting a minimum distance of 18-21m between facing homes. These are still useful yardsticks for visual privacy, but adhering rigidly to these measures can limit the variety of urban spaces and housing types in the city, and can sometimes unnecessarily restrict density.

Instead, designers are required to demonstrate how the design as a whole uses a variety of measures to provide adequate visual and acoustic privacy for every home. Designers should consider the position and aspect of habitable rooms, gardens and balconies, and avoid windows that directly face each other where privacy distances are tight. It will often be beneficial to provide a set-back or buffer where habitable rooms directly face a public thoroughfare, street, lane or access deck.

Standards

5.1.1

Design proposals should demonstrate how habitable rooms within each dwelling are provided with an adequate level of privacy in relation to neighbouring property and the street and other public spaces.

5.2

Dual Aspect

A home with opening windows on at least two sides has many inherent benefits, including better daylight, a greater chance of direct sunlight for longer periods, cross ventilation, a choice of views, access to a quiet side of the building, and a greater flexibility in the use of rooms. The Mayor believes dual aspect should be the first option that designers explore for all new developments.

A dual aspect dwelling is one with opening windows on two external walls, which may be on opposite sides of the building or around a corner. One aspect may be towards an external access deck or courtyard, although the layout of the dwelling needs to be carefully considered in these cases to maintain privacy.

Where limited rooms are required, the frontage is generous, the plan is shallow, and the orientation is favourable, good single aspect one- and two- bedroom homes are possible. In single aspect dwellings with more than two bedrooms, it is difficult to achieve adequate ventilation and daylight to all rooms in an efficient plan layout which avoids long internal corridors. Even where this is possible, the outlook will lack variety and many ancillary spaces will be internal.

Standards

5.2.1

Developments should avoid single aspect dwellings that are north facing, exposed to noise exposure categories C or D⁴¹, or contain three or more bedrooms.

5.2.2

Where single aspect dwellings are proposed, the designer should demonstrate how good levels of ventilation, daylight and privacy will be provided to each habitable room and the kitchen.



5.3 Noise

Noise from adjoining properties, from the street and from common areas of the building can be a common cause of stress, sleep disturbance and friction between neighbours. Research suggests that people's perception of privacy in the home is affected by noise as much as by visual privacy⁴². The aim should be to exceed the minimum standards set out in Building Regulations Part E in line with the target levels of the Code for Sustainable Homes.

The layout and placement of rooms within the building should be considered at an early stage in the design process to limit the impact of external noise on bedrooms and living rooms. The impact of noise should also be considered in the placement of private external spaces.

The following are general considerations for good practice:

- Limiting noise from external sources including road, rail and air traffic, and noise-generating public and business uses, by orientating sound-sensitive rooms to face quieter external spaces.
- Designing larger developments to create quieter external spaces between dwellings.
- Planning building and dwelling layouts to limit the transmission of airborne and impact sound from common areas, lifts and refuse chutes.
- Planning dwelling layouts to limit noise transmission between adjacent dwellings by arranging bedrooms of adjacent dwellings next to, and above, one another, rather than living rooms above bedrooms.
- Taking measures to limit reverberation within internal common circulation areas.
- Limiting sound transfer within the

individual dwelling by ensuring that walls between bedrooms and the living room and WCs provide adequate resistance to the passage of sound.

Further advice is given in the London Plan SPG on Sustainable Design and Construction⁴³.

Designers are encouraged to make use of Robust Details as a design tool whether or not they are used to satisfy Building Regulations⁴⁴.

Standards

5.3.1

The layout of adjacent dwellings and the location of lifts and circulation spaces should seek to limit the transmission of noise to sound sensitive rooms within dwellings.

5.4 Floor to Ceiling Heights

The height of rooms in a dwelling dramatically affects the perception of space in a home. A small increase in ceiling height can make the difference between a home feeling cramped or generous. When matched with generous window sizes, higher ceilings also improve natural light levels and ventilation, and the depth to which light penetrates a room.

In ground floor dwellings where daylight may be limited, higher ceilings can provide better light levels, a better urban scale to the base of larger buildings, the potential for homes to be used more flexibly, and can make ground floor dwellings more suitable for conversion to non-residential uses.

In habitable rooms, ceiling heights will be expected to be at least 2.5m, with a preference for 2.6m or more. Rooms with sloping ceilings beneath pitched roofs should achieve the minimum ceiling heights in at least 60% of the area of the room.

For projects creating new dwellings in existing buildings and developments in sensitive historic contexts, including infill developments within conservation areas, lower ceiling heights may be permitted by the local borough.

Standards

5.4.1

The minimum floor to ceiling height in habitable rooms is 2.5m between finished floor level and finished ceiling level. A minimum floor to ceiling height of 2.6m in habitable rooms is considered desirable and taller ceiling heights are encouraged in ground floor dwellings.



5.5 Daylight and Sunlight

Daylight and sunlight animate indoor spaces and enhance the appearance and residents' enjoyment of an interior. Views out keep people in touch with their wider surroundings, the prevailing weather, and the rhythm of the day and seasons. Good natural light reduces the energy needed to provide light for everyday activities, while controlled sun penetration can also help to meet part of the winter heating requirement⁴⁵.

Daylight

The quality and quantity of natural light in an interior depends on both the surrounding environment and the design of the building – the size and position of windows, the depth and shape of rooms, and the colours of internal surfaces. Bear in mind that it is easy for people to manage light levels if there is too much daylight, but impossible to do anything about it if there is too little.

The Code for Sustainable Homes requires a minimum average daylight factor of 2% in kitchens and 1.5% in living rooms, dining rooms and studies in order to achieve credits. These measures define a minimum acceptable level of natural light to make an interior feel day-lit, but they do not guarantee a comfortable level of light for a range of daily activities. The desirable standard for the minimum area of glazing in habitable rooms set by this guide sets out to achieve that higher measure of comfort.

Sunlight

Provided that it can be controlled, people love sunlight, and likewise its absence has a damaging effect. This guide therefore requires all new homes to provide for direct sunlight to enter at least one habitable

room for part of the day. Sunlight is especially desirable in living areas and kitchen dining spaces as these are the rooms most likely to be used for long periods. The needs of people who spend a large proportion of their day indoors, including older people, demand particular consideration.

Sunlight can have a significant impact on thermal comfort and energy consumption. In winter it can make an important contribution to heating, but excessive solar gain can cause discomfort in summer. In general the best control of sunlight is achieved through the careful positioning and sizing of windows according to the function of spaces and their orientation. Fixed projections above windows, including balconies, can be designed to screen high summer sun while admitting low winter sun and deciduous trees also provide useful seasonal shading.

Standards

5.5.1

Glazing to all habitable rooms should be not less than 20% of the internal floor area of the room.

5.5.2

All homes must provide for direct sunlight to enter at least one habitable room for part of the day. Living areas and kitchen dining spaces should preferably receive direct sunlight.

6.0

Climate Change Mitigation and Adaptation

The Mayor is committed to making London a world leader in tackling climate change. The London Plan seeks to ensure that all new housing reduces carbon emissions, conserves water, mitigates flooding and safeguards biodiversity.

An understanding of climate and ecology is necessary not just to contribute to the Mayor's drive to address the city's carbon emissions, but also to make

homes that are comfortable in hot summer months and well insulated for the winter.

This section highlights the requirements of the London Plan, which are linked to Code for Sustainable Homes guidance and national targets for achieving zero net carbon emissions in all new housing by 2016.

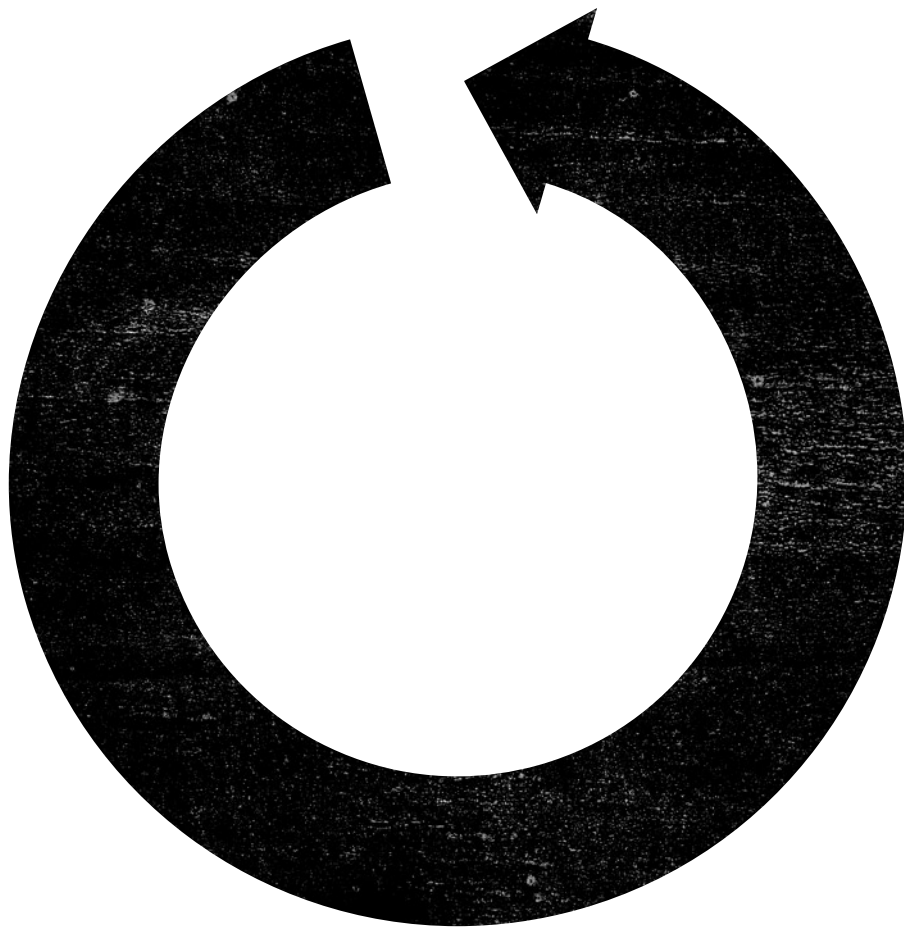



6.1 Environmental Performance

Central government and the Mayor have committed to making all new housing zero carbon by 2016. A zero carbon home is one whose net carbon dioxide emissions, taking account of emissions associated with all energy use, is equal to zero or negative across the year. The definition of 'energy use' covers both energy uses currently regulated by the Building Regulations and other energy used in the home.

The Code for Sustainable Homes is the national performance standard for sustainable housing. The London Housing Strategy says that all new publicly funded homes in London must meet code level 3 between 2008 and 2011 as a minimum requirement. This guide applies to the next funding round for new affordable homes from 2011 onwards, therefore requirement 6.1.1 in this guide sets a target of code level 4. This is a step change from the level 3 requirement of the 2008-11 London Housing Strategy.

However, there are opportunities to go much further. Priority funding is already given to homes that exceed level 3, and the Mayor's Targeted Funding Stream supports schemes reaching levels 5 or 6.

This guide sets a target of Code level 4 for all new housing. To achieve this, new developments will need to be designed and constructed to make the fullest contribution to climate change mitigation and adaptation. This means minimising overheating, reducing flood risk, improving water efficiency and protecting and enhancing green infrastructure, as well as taking steps to reduce carbon dioxide and other greenhouse gas emissions.

Standards

6.1.1

Designers should seek to achieve a minimum of Level 4 of the Code for Sustainable Homes in all new developments.

6.1.2

All homes should satisfy London Plan policy on sustainable design and construction and make the fullest contribution to the mitigation of and adaptation to climate change.

6.2

Energy and CO2

The Mayor has set targets, over and above national ones, for reducing carbon emissions and generating energy in London. By 2025 the Mayor seeks to achieve a reduction in London's overall carbon dioxide emissions of 60 per cent below 1990 levels and expects 25 per cent of heat and power used in London to be generated in local, decentralised energy plants.

Meeting Code level 4 requires a 44 per cent improvement in energy efficiency beyond Building Regulations Part L 2006. The code does not prescribe how to achieve this target, but the London Plan requires that all developments adopt the following hierarchy of priorities for providing energy for heating, lighting, and cooling the home⁴⁶:

- Lean: using less energy in construction and operation by incorporating sustainable design and construction measures, and by specifying energy-efficient lighting and appliances;
- Clean: supplying energy efficiently by prioritising decentralised energy generation⁴⁷; and
- Green: using renewable energy

Lean: Using Less Energy

Before decentralised or renewable energy technologies are considered, the first priority is to reduce energy consumption. This means making the building fabric more efficient to minimise energy loss, taking steps to reduce the need for electric lighting, heating, mechanical ventilation and cooling and the specifying energy efficient lighting and appliances.

Key design considerations include:

- Maximising the controlled use of

passive solar energy in the layout and orientation of buildings and design of windows;

- Maximising the use of passive ventilation;
- Using energy-efficient window glazing and frames;
- Increasing air tightness in the building envelope;
- Making appropriate use of thermal mass and insulation; and
- Installing energy-efficient lighting and appliances.

Clean: Supplying Energy Efficiently

The Mayor's second priority is supplying energy more efficiently through decentralised energy generation, through small energy sources generating electricity and heat near the point of use.

The London Plan expects all major new developments to connect into existing heating and cooling networks, or provide site-wide CHP (Combined Heat and Power) networks where feasible, unless site-specific solutions combining low carbon or renewable energy generation achieve a greater reduction in CO2 emissions⁴⁸.

Green: Using Renewable Energy

Where feasible, development proposals should incorporate on-site renewable energy generation to reduce carbon dioxide emissions. Renewable energy generation methods include solar thermal systems, biomass-fuelled heating and/or power, ground source heating and cooling, air source heat pumps, photovoltaics, wind power, and renewable energy from waste⁴⁹.

Standards

6.2.1

Development proposals should be designed in accordance with the London Plan energy hierarchy, and should meet the following minimum targets for carbon dioxide emissions reduction.

Year	Improvement on 2006 Building Regulations
2010 - 2013	44 per cent
2013 - 2016	55 per cent
2016 - 2031	Zero carbon

6.3 Overheating

Overheating is an increasing concern for homes in London. It is predicted that temperatures will rise due to climate change and London is likely to be warmer than surrounding areas due to the 'urban heat island' effect, caused by waste heat generated by energy use and retained by the materials in the urban environment. As homes are made more airtight and energy efficient, care must be taken to limit the risk of overheating.

In accordance with the London Plan Sustainable Design and Construction SPG this guide promotes dual aspect dwellings, which help to make natural ventilation more effective in hot weather (see section 5.2). Designers should also consider controlling solar gain in summer by using fixed or adjustable shading devices and planting deciduous trees to achieve shading in the summer.

Standards

6.3.1

Development proposals should demonstrate how the design of dwellings will avoid overheating during summer months without reliance on energy intensive mechanical cooling systems.



6.4 Water

Water Use

Demand for water is rising as London's population grows, and the hotter, drier summers predicted as a result of climate change are likely to increase demand further and reduce availability. Less predictable rainfall patterns will also make it more difficult to retain the water that does fall.

To achieve Code Level 4, water fittings and appliances should consume no more than 105 litres per person per day.

Flood Risk and Managing Surface Water Run-Off

London is prone to flooding from five sources: tidal, fluvial, surface water, sewer and groundwater flooding. Climate change is likely to increase the likelihood of flooding from the first four sources. Flood risk can be reduced by locating new developments in appropriate places, through design and construction, and by managing surface water run-off.

The government's PPS25 and the Code for Sustainable Homes aim to encourage housing development in low flood risk areas and to take measures to reduce the impact of flooding on houses built in medium or high risk areas. Under the London Plan, flood risk should be assessed in accordance with PPS25. Where development in areas at risk from flooding is permitted, management and mitigation measures should be implemented.

Managing surface water run-off from new developments is a mandatory requirement of the Code for Sustainable Homes.

London Plan policies on sustainable

drainage set out the expectations for developers to manage flood risk. Sustainable Urban Drainage Systems (SUDS) techniques include permeable paving, soakaways, storm water retention, green roofs, soft landscaping, holding ponds, swales and reed beds.

Green roofs should be incorporated within developments wherever possible. Green roofs contribute to biodiversity, reduce heat loss from buildings and help to mitigate the urban heat island effect. Green roofs can also be designed to provide amenity space.

Standards

6.4.1

New dwellings should be designed to ensure that a maximum of 105 litres of water is consumed per person per day⁴⁹.

6.4.2

Where development is permitted in an area at risk of flooding, it should incorporate flood resilient design in accordance with PPS25⁵⁰.

6.4.3

New development should adhere to standards for surface water run-off as set out in the Code for Sustainable Homes⁵¹.

6.4.4

New development should incorporate Sustainable Urban Drainage Systems and green roofs where appropriate⁵².

6.5 Materials

Embodied energy is becoming an increasing proportion of the overall lifetime construction and operational energy use of buildings. Efforts should be made to reduce the embodied energy of the construction process and materials used in construction.

The Code for Sustainable Homes assesses the embodied environmental impact of construction products and materials used in the roofs, external and internal walls, ground and upper floors, and windows of buildings through the Green Guide ratings⁵³. As a mandatory requirement of the Code, at least three of the five aspects of the building envelope should achieve a Green Guide rating between A+ and D. A further nine credits are available for the responsible sourcing of materials.

The London Plan Sustainable Design and Construction SPG⁵⁴ also provides standards for the use of materials based upon the principles of:

- procuring and using materials sustainably;
- selecting materials with low lifecycle impacts;
- using local materials; and
- using an appropriate palette of materials.

Re-used and recycled materials, or materials with a high recycled content, should also be used where possible as these can significantly reduce the embodied energy in new development.

Standards

6.5.1

All new residential development should meet the requirements of the Code Level 4 with regard to using materials with lower environmental impacts over their lifecycle⁵⁵.

6.5.2

All new residential development should accord with Code for Sustainable Homes Level 4 and the London Sustainable Design and Construction SPG with regard to the sourcing of materials⁵⁶.



6.6 Ecology

The Code for Sustainable Homes says that development should avoid building on land of ecological value and wildlife habitat. Where possible, development should enhance the ecological value of a site. The code seeks to protect the natural environment during construction and promotes efficient building footprints. It is vital to make the best use of land to ensure that development does not adversely affect habitats and ecologies.

London Plan policy regarding biodiversity and nature conservation promotes a proactive approach to the protection, promotion and management of biodiversity across the capital. The GLA's best practice guidance relating to Development Plan Policies for Biodiversity provides advice on the conservation and enhancement of the biodiversity and natural heritage of London⁵⁷. Proposals for development should give full consideration to their direct and indirect effects on ecology.

Standards

6.6.1

The design and layout of new residential development should avoid areas of ecological value and seek to enhance the ecological capital of the area in accordance with GLA best practice guidance on biodiversity and nature conservation⁵⁸.

6.7 Other Considerations

The Code for Sustainable Homes covers a range of other tradable criteria, including pollution, health and wellbeing and management.

The code measures pollution inside the building resulting from insulation and heating systems. The London Plan sets out an approach to improving air quality and to contaminated land. Further information is provided in section 2.4.3 of the London Sustainable Design and Construction SPG, based on the principles of minimising emissions from building services and protecting internal air quality.

Other criteria covered in the code such as waste and recycling, Lifetime Homes, daylighting and noise are covered separately in other parts of this guide. Some of these which are currently tradable in the code or mandatory only at higher levels (such as Lifetime Homes) are already mandatory for London as required by the London Plan and indicated in this guide.

7.0

Managing the Design Process

Excellence in design will not be achieved just by applying a set of design standards. The quality of the end result will depend on two other factors: the strength of the client's design management process and the quality of the project team.

Great design requires great designers, and the section below on design team selection should be taken seriously. London needs a variety of design expertise to overcome the challenges outlined in this guidance.

This section suggests a model process for design management (that can be used with any procurement method) and proposes a series of principles for design team selection and post-construction management. These recommendations are based on the Design Management Process set out in 'Standards and Quality in Development: A Good Practice Guide', 2008, by HATC Ltd for the National Housing Federation. This is recommended as a source of further information. Additional references are provided at the end of the chapter.

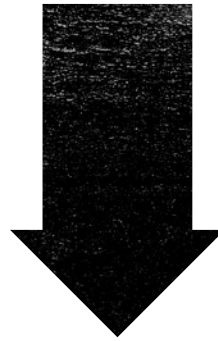
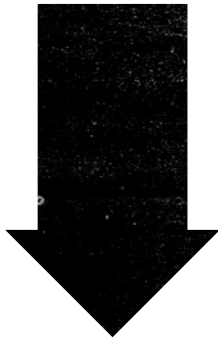
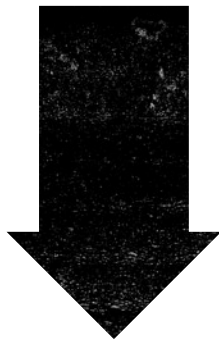

7.1 The Client Role

The client's role in managing the design process is to set out the parameters and requirements of the project, to create a clear framework for the work of the project team, to establish and manage the project timescales, and to make decisions.

Effective design management relies on the client successfully fulfilling the following key roles:

- Carefully considering what the project needs to achieve
- Writing a clear and thought-through brief
- Selecting an appropriate design team
- Fully briefing the design team
- Encouraging and allowing time for the design team to think carefully before proposing designs
- Ensuring that decisions are made in sequence and in a timely manner
- Freezing design decisions at key stages
- Ensuring that the management of the building when complete is considered during the design process.

The client will need to decide whether to appoint a design team leader, or whether they will themselves carefully manage the scope of each member of the design team, to ensure that there are no gaps or duplications.

The resourcing and decision making structure of the client design management process requires careful consideration. Projects where the decision-maker consists of a group of people can be successful, whereas projects managed by committee are rarely successful. Projects managed by a client design leader in consultation with stakeholders and projects are often successful.

7.2 Design Team Selection

Good housing requires a skilled design team, capable of understanding the demands of the brief and the complexities and opportunities of the site. A skilful design team will help to optimise designs, maximise value and provide higher quality than a less able team. All design teams will perform much better if they are actively managed and led by the client, rather than left to their own devices.

A designer's track record is a good indication of their suitability. However, clients can restrict the field of selection unnecessarily where they consider only large architectural practices or multi-disciplinary firms. Often, new architectural talent can come up with fresher ideas than those with experience of the status quo. Clients are therefore encouraged to balance experience and design flair in their selection criteria, to offer opportunities for as broad a range of design talent as possible in projects. It is not necessary to do so, but sometimes supporting smaller firms within a design team composed of experienced partners can yield good results. Larger regeneration schemes with a number of projects of varying complexity and scale often present opportunities for a mix of designers to be involved, and this

can positively influence the diversity and quality of the resulting environment.

Team selection should be made on the basis of design ability and best value, first and foremost. A team that brings excellent design will often offer better value than consultants who just meet the baseline standard but offer a lower price.

Proper time and attention should be given to identifying the appropriate range of consultant skills before selecting the design team. Almost all projects require the support of a range of consultants, which may include landscape architects, structural and services engineers, traffic and highways engineers, and sustainability and environmental consultants. It is recommended that the full design team is appointed at the inception of the project. Experience has shown that delaying these appointments can often compromise quality, budget, or the success of the planning application.

The selection of the design team should ideally involve at least one expert design adviser (design champion) who will be involved in design review for the duration of the project.

7.3 The Design Process

The diagram below illustrates the typical responsibilities of the design team, the client team and the planning team in each project stage, linked to the RIBA Plan of Work.

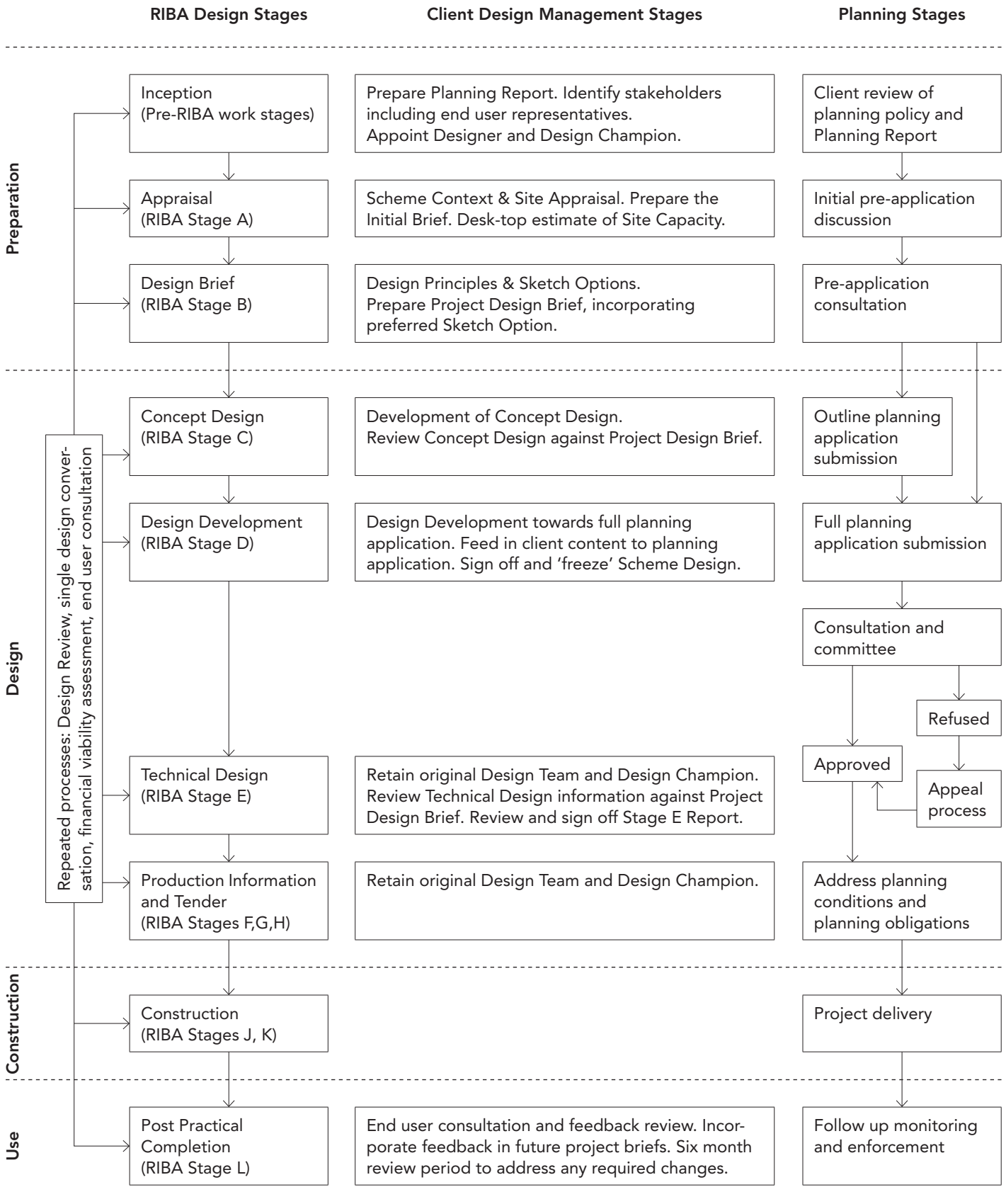

7.4 The Design Process from Inception to Planning

In the early stages of the project it is essential to provide the design team with a strong management framework and sufficient time and resource, as this is the stage at which the fundamentals of the design are decided.

A common scenario is that an initial sketch scheme produced hastily to establish site capacity is simply taken forward as the scheme design with little further refinement. This produces demonstrably poorer results when compared to projects with well written and thought-out briefs, and adequate time for design development. Rushing the initial stages creates several risks:

- The client can incur costly and time-consuming design changes late in the process because of an incomplete or inadequate initial brief to the design team;
- The client can fail to maximise the opportunities of a site if it does not allow the design team enough time to develop and test the design;
- A project might need a comprehensive redesign if the client does not allow enough time for consultation with the local planning authority and other decision makers early in the process.

These pitfalls can be avoided if the client controls the timescales of the project and clearly explores and sets out their own requirements. Developing the brief, testing initial design options, and arriving at a preferred concept design should be a step-by-step process.

Below is a proposed structure for managing the design process from inception to planning, which is expanded on the following pages. The stages are:

- Planning Report, produced by the client
- Initial Brief, produced by the client
- Scheme Context and Site Appraisal, produced by the client

- Design Principles, produced by the client with the aid of the designer
- Sketch Options
- Design Brief (RIBA Stage B)
- Concept Design (RIBA Stage C)
- Scheme Design (Stage D) and planning submission

At the end of each of stage, a design review should be undertaken testing the proposals against the brief, design objectives and project budget. Design reviews should include the client, design team, design champion, and it is recommended they also include the client's operational staff and a representative from an end user organisation such as a tenants' and residents' association, where one exists. The results of each design review need to be properly recorded, including details of any consultation process undertaken (for instance with CABE or the local community), and the reasons for adopting, or rejecting, any comments received.

Taking a design successfully through the planning process can be greatly helped with the arrangement of a single design conversation. This is framework a for discussion which allows the priorities of the client, stakeholders and local planning authority to be heard and debated simultaneously, in order to reach an early consensus on key design priorities and constraints. Even a relatively small project may require consultation with one or more planning authorities, design officers representing stakeholders such as London Borough, English Heritage, Design for London, the LDA, CABE or the HCA. By creating the framework for a single design conversation from the start of the process, the potentially contradictory priorities of stakeholders can be resolved and the risk of conflicts emerging in later stages eliminated. This unified conversation

» **The Design Process from Inception to Planning** *continued*

may involve one or more design review meetings at which decision makers and stakeholders are present, so that design

concerns and potential conflicts can be shared and discussed with the design team.

Key Stages in Design Management from Inception to Planning:

1. Planning Report	
<p>Before writing the brief for a site or assessing the suitability of a design proposal, the client should be fully aware of any constraints on development. The client should research local authority policies relating to the site and other constraints including requirements of the site freeholder or subsidy provider. Both existing planning policies and any potential changes in the pipeline should be identified.</p> <p>The client should ensure that either they or the design team prepare a site-specific report detailing the implications</p>	<p>of planning policy and other constraints on the scheme design, in particular highlighting the likely impact of parking, refuse disposal, and design and density standards. This report should form part of the initial brief.</p> <p>If an assessment of site capacity is required at this stage, the designer should be asked to undertake a desk-top study based on the above constraints, rather than proposing any designs.</p>
2. The Initial Brief	
<p>The initial brief setting out the client's broad requirements should be produced before any design decisions are taken. A clear initial brief is a prerequisite for assessing whether or not design proposals achieve the client's objectives.</p> <p>The initial brief should include key background information, client objectives and required performance standards, which may include:</p> <ul style="list-style-type: none"> • The preferred dwelling density, mix and the degree of integration/separation of dwellings and tenures and proposed long-term management arrangements; • The client's standard design brief with any amendments arising from feedback on other recent schemes; 	<ul style="list-style-type: none"> • The proposed extent of any external consultation required at this stage; • The standards in this document and any other specific requirements that can affect the design, such as the preferred approach to the Code for Sustainable Homes, targeted Building for Life criteria, the provision of non-housing amenities, or other requirements; • The status of specific standards, (ie essential, recommended, desirable); legal or other encumbrances on the site that may impact upon the design.
3. Scheme Context and Site Appraisal	
<p>A Scheme Context and Site Appraisal produced by the client or design team should consider how the surrounding context may influence design options and scheme costs. This is likely to cover:</p> <ul style="list-style-type: none"> • The character and built form of the surrounding area; • The relationship of the site to its surroundings; if a cleared site, the previous street/open space patterns; • Pedestrian routes through and near the site; walking distance to public transport and amenities; • The legal constraints such as restrictive covenants, Section 106 agreements, rights of way, site and boundary ownership; 	<ul style="list-style-type: none"> • The potential for the site to be improved or enhanced, for example by land exchange; • The topography, landscape, buildings and soil features of the site that should be retained or exploited in any development to enhance its sense of place; • The impact that the development of the site will have on the ecology/environment of the surrounding area; • Ground investigations, covering bearing capacity, contamination, etc.

4. Design Principles	
<p>Before sketch options are produced, the design team should be asked to propose a set of design principles for the development which the client should consider and amend or confirm as part of a draft project design brief. The design principles will be based on the client’s site appraisal, initial brief, and the report on planning and other local authority policies.</p> <p>The design principles are likely to cover:</p> <ul style="list-style-type: none"> • Entry points to the site and points of connection to surrounding area; 	<ul style="list-style-type: none"> • Treatment of the edge of the development in relation to its surroundings; • Approach to energy efficiency / Code for Sustainable Homes; • Approach to landscape design and the provision of open spaces and play spaces; • Retention or removal of existing features; • The amount and location of car parking; • The priorities for spending the resources available.
5. Sketch Options	
<p>The designer will then be able to produce sketch options in line with the initial brief and design principles for the client to cost. The preferred option, together with the project</p>	<p>objectives and more specific information (such as targeted use, tenure and/or unit mixes) will then become the project design brief required by the design team at RIBA Stage B.</p>
6. Project Design Brief (RIBA Stage B)	
<p>The Project Design Brief will now contain:</p> <ul style="list-style-type: none"> • The report on planning etc, • The requirements of the initial brief, • The findings of the context and site appraisal investigations, • The design principles. The preferred sketch option • Any feedback from previous schemes 	<p>Feedback from end users (residents and operators) is extremely helpful in gaining an understanding of how previous designs have performed over time. The client should maintain good quality feedback records and incorporate findings into subsequent project briefs.</p>
7. Concept Design (RIBA Stage C)	
<p>The project design brief should allow the design team to move on to concept design stage (RIBA Stage C) and develop the preferred option and provide outline proposals for structural and building services systems, outline specifications and a</p>	<p>preliminary cost plan. The client should review concept designs and confirm whether they meet their requirements before committing to the scheme.</p>
8. Design Development to Full Planning (RIBA Stage D)	
<p>By the end of this stage, the concept design will have been developed to the level of detail needed for a full planning application, and all significant design decisions will have been taken on questions of use, amount, layout, scale, appearance and landscaping. At this stage, the client should commit to making no further changes to key design decisions, effectively “freezing” the design. Design development from this stage should be a process of refinement of decisions already made, working towards technical resolution.</p>	<p>This ensures that careful work undertaken by the client up to this point is not subsequently lost, and avoids costly delays relating to redesign in the later stages of the project. A design champion, whose role is to monitor and safeguard design quality from inception to detailed design and construction phases, can help ensure continuity and quality in delivery.</p>

Managing Design through the Work Stages

Design principles agreed during the early design stages must not be lost after Stage D, during technical design or later. The client needs to decide, with its lead consultant, how control over the design is to be maintained through the later stages of design and construction. Different mechanisms may be appropriate depending upon the type of construction contract and who has responsibility for further developing the design – the client, architect or building contractor.

Any potential changes to the requirements should be analysed in terms of their impact on the programme, cost plan, quality, work of consultants, and planning.

Contractor Procurement

A construction procurement route should be selected that safeguards the project's original design intent throughout the implementation stage should be selected. A significant element of design quality is won or lost after Stage D, and that quality is relatively easily lost unless the client continues to demand it.

Clients can seek to minimise risks to design quality by using a traditional form of building contract and ensuring that the original design team is responsible for design development all the way through the RIBA Work Stages. Generally, when clients transfer financial risk to contractors by using design and build contracts they expose themselves to the risk of a reduction in design quality. Where a design and build contract is used, a client may improve their control of design risk by providing the main contractor with detailed employer's requirements and reserving the right to comment on design details, using the original design team as advisors. The quality may also be improved by selecting a contractor who is enthusiastic about design, not just building.

Another key principle is that design development should be completed before the contractor is appointed. In a Design and Build or Partnering process this means developing the design, including key architectural details, to RIBA Stage E. There should be a bias away from any form of procurement that limits design development prior to the appointment of the contractor.

An independent design advisor should be appointed with a remit to monitor and safeguard design quality throughout the process.

Forward Planning for Management and Maintenance

All new developments that involve shared or communal areas must have robust management structures that deliver a secure, supportive and safe environment, and provide for management and maintenance activities including the cleaning of common parts, maintenance of lifts, upkeep of landscaping, management of parking and collection of service charges. Where the landlord is an RSL, a lettings and allocation plan is also required.

A joint management plan, specifying how the freeholder or landlord(s) will manage and maintain the development and the structures for ongoing leaseholder or tenant consultation, should be drafted prior to planning stage and should preferably be formally agreed at least six months prior to Practical Completion. This plan should:

- State the means of communication between the freeholder or landlord management company and leaseholders or tenants, and how leaseholders and tenants will be informed of their rights and obligations under the agreement.
- Demonstrate that satisfactory levels of security can be achieved and include measures to address antisocial behaviour, where relevant.
- State how the parking allocation, including blue badge bays, will be managed.

- Set out the anticipated initial ground rent and service charges, and the process by which these will be changed in the future.
- Set out objectives and standards specifying the quality of maintenance works and the method of response to reports of failure (e.g. lift breakdown), as well as the frequency and scope of cyclical works. Specify how maintenance works will be funded, and any charges the freeholder or landlord management company may make for procurement and management of these works.
- Provide a schedule of the amenities to which residents will have access, detailing any service charges relating to the amenities and how these will be decided in future.
- Describe the forum and process for leaseholders and/or tenants to discuss management and maintenance with the landlord, and agree changes in procedures and obligations.

References

Standards and Quality in Development:
A good practice guide, (second edition)
HATC, National Housing Federation, ISBN
978 0 86297 539 5, 2008

Capital Gains: Making high density
housing work in London, London Housing
Federation, May 2002

Creating Excellent Buildings: A guide for
clients, CABI, October 2003

Recommendations for Living at
Superdensity, Design for Homes, June 2007

Appendices

1 Space Standards Study

2 Furniture Schedule

3 Wheelchair User Housing Design Standards



4 Definitions

5 References

Appendix 1 – Space Standards Study

This study of room sizes relative to designed occupancy levels is the basis of the minimum space standards (GIA) of Standard 4.1.1. To develop the space standards, each type of room was planned around the furniture listed in Appendix 2 and activity and access requirements. The GIA is the cumulative total of room areas plus an allowance for circulation and partitions.

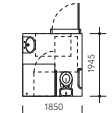
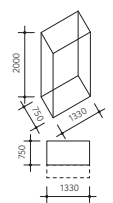
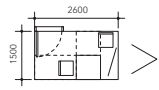
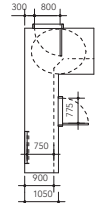
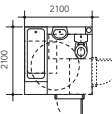
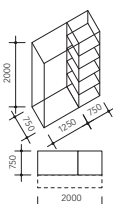
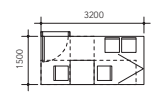
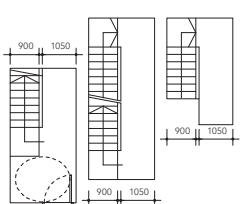
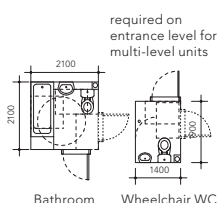
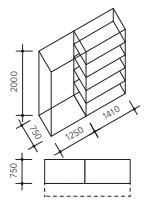
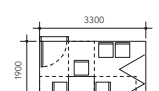
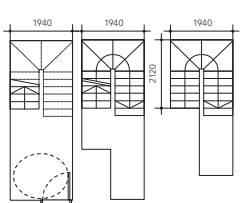
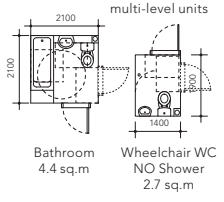
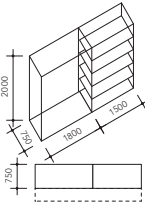
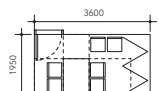
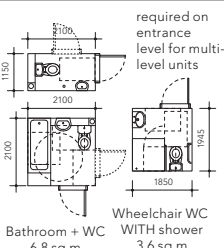
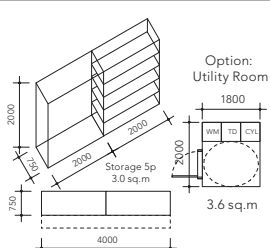
	Kitchen <small>*see key to kitchen items</small>	Dining <small>dining area calculated as difference of kitchen dining and kitchen</small>	Living	Combined Kitchen/Living/Dining:	Double	Twin	Single
1-person	 6.2 sq.m	 9.4 sq.m dining area 3.2 sq.m	 12.0 sq.m	21 sq.m			 Bedspace 8.0 sq.m
1-bed, 2-persons	 6.8 sq.m	 10.4 sq.m dining area 3.6 sq.m	 13.0 sq.m	23 sq.m	 Double Bedroom 12.0 sq.m		
2-bed, 3-persons	 7.5 sq.m	 11.2 sq.m dining area 3.6 sq.m	 14.0 sq.m	25 sq.m	 Double Bedroom 12.0 sq.m		 Single Bedroom 8.0 sq.m
2-bed, 4-persons	 7.5 sq.m	 12.0 sq.m dining area 4.5 sq.m	 14.8 sq.m	27 sq.m	 Double Bedroom 12.0 sq.m	 Twin Bedroom 12.0 sq.m	
3-bed, 5-persons	 8.3 sq.m	 12.8 sq.m dining area 4.5 sq.m	 16.0 sq.m	29 sq.m	 Double Bedroom 12.0 sq.m	 Twin Bedroom 12.0 sq.m	 Single Bedroom 8.0 sq.m
4-bed, 6-persons	 9.6 sq.m	 14.4 sq.m dining area 4.8 sq.m	 17.0 sq.m	31 sq.m	 Double Bedroom 12.0 sq.m	 Twin Bedroom 12.0 sq.m	 2 Single Bedroom 16.0 sq.m

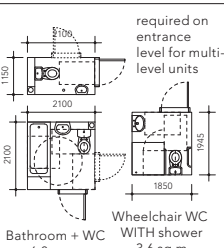
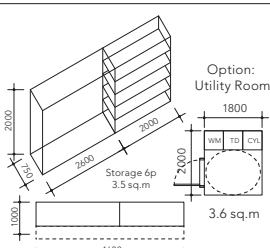
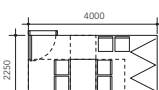
Bathroom	Storage/Utility	Outdoor Amenity Space	Net Internal	Circulation:	Partition walls allow 5 %	GIA [exc. amenity]	Circulation Layouts Stairs for 3m floor to floor height 15 steps 230/200
 <p>Shower Room 3.6 sq.m</p>	 <p>Storage 1p 1 sq.m</p>	 <p>4 sq.m</p>	33.5 sq.m	1 Level Flat + 1.5 sq.m	2 sq.m	37 sq.m	 <p>one level flat circulation area 6.5-12.5 sqm</p>
 <p>Bathroom 4.4 sq.m</p>	 <p>Storage 2p 1.5 sq.m</p>	 <p>5 sq.m</p>	41 sq.m	1 Level Flat + 6.5 sq.m	2.5 sq.m	50 sq.m	 <p>ground level 1st level 2nd Level two storey house circulation area 19 sqm three storey house circulation area 25 sqm</p>
 <p>Bathroom 4.4 sq.m</p> <p>Wheelchair WC NO Shower 2.7 sq.m</p> <p>required on entrance level for multi-level units</p>	 <p>Storage 3p 2.0 sq.m</p>	 <p>6 sq.m</p>	51.5 sq.m	1 Level Flat + 6.5 sq.m	3 sq.m	61 sq.m	 <p>ground level 1st level 2nd Level Alternative stair configuration</p>
 <p>Bathroom 4.4 sq.m</p> <p>Wheelchair WC NO Shower 2.7 sq.m</p> <p>required on entrance level for multi-level units</p>	 <p>Storage 4p 2.5 sq.m</p>	 <p>7 sq.m</p>	58 sq.m	1 Level Flat + 8.5 sq.m	3.5 sq.m	70 sq.m	
 <p>Bathroom + WC 6.8 sq.m</p> <p>Wheelchair WC WITH shower 3.6 sq.m</p> <p>required on entrance level for multi-level units</p>	 <p>Storage 5p 3.0 sq.m</p> <p>Option: Utility Room 3.6 sq.m</p>	 <p>8 sq.m</p>	71 sq.m	1 Level Flat + 10.5 sq.m	4.5 sq.m	86 sq.m	
 <p>Bathroom + WC 6.8 sq.m</p> <p>Wheelchair WC WITH shower 3.6 sq.m</p> <p>required on entrance level for multi-level units</p>	 <p>Storage 6p 3.5 sq.m</p> <p>Option: Utility Room 3.6 sq.m</p>	 <p>9 sq.m</p>	81.5 sq.m	1 Level Flat + 12.5 sq.m	5.0 sq.m	99 sq.m	<p>Variations</p> <p>3-bed, 4-persons 1 level flat: 70-12+(8x2) = 74 sq.m 2 storey house: 83-12+ (8x2) = 87 sq.m 3 storey house: 87+6 = 93 sq.m</p> <p>3-bed, 6-persons 1 level flat: 99-16+12 = 95 sq.m 2 storey house: 107-16+12 = 103 sq.m 3 storey house: 113-16+12 = 109 sq.m</p> <p>4-bed, 5-persons 1 level flat: 86-12+(8x2) = 90 sq.m 2 storey house: 96-12+ (8x2) = 100 sq.m 3 storey house: 102-12+ (8x2) = 106 sq.m</p>
			82.5 sq.m	2 Storey House + 19 sq.m	5.5 sq.m	107 sq.m	
			82.5 sq.m	2 Storey House + 25 sq.m	5.5 sq.m	113 sq.m	
<p>*Key to Kitchen Items</p> <ul style="list-style-type: none"> AE Ancillary Equipment BU Base Unit CYL Hot Water Cylinder DR Drawers DW Dishwasher-optional FF Fridge Freezer RB Recycle Bins SU Storage Unit T Tray Space WM Washing Machine 							

Appendix 2 - Furniture Schedule

The following schedule of furniture should be shown on dwelling plans to demonstrate Requirement 4.1.2. The furniture formed the basis of the Space Standards Study in Appendix 1.

Kitchen Furniture Schedule

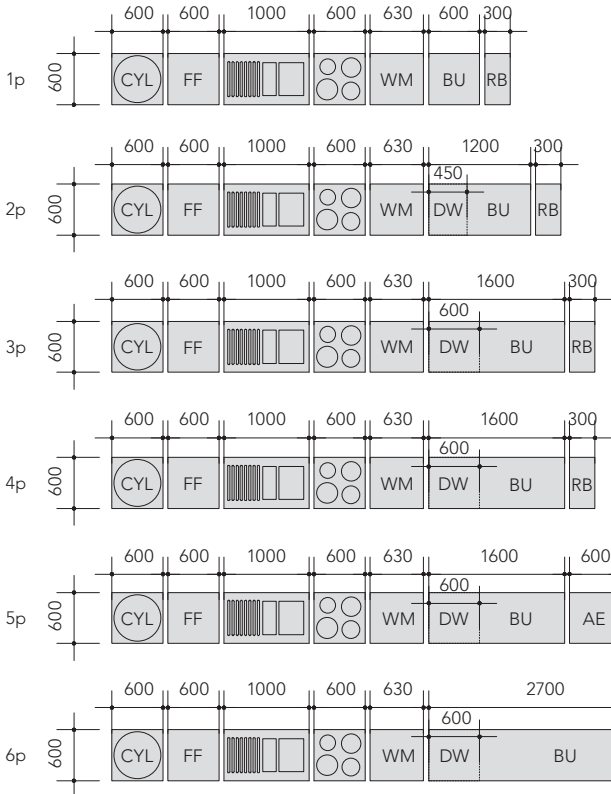

- Key to Items
- AE Ancillary Equipment
 - BU Base Unit
 - CYL Hot Water Cylinder
 - DR Drawers
 - DW Dishwasher-optional
 - FF Fridge Freezer
 - RB Recycle Bins
 - SU Storage Unit
 - T Tray Space
 - WM Washing Machine

Dining Space Furniture Schedule

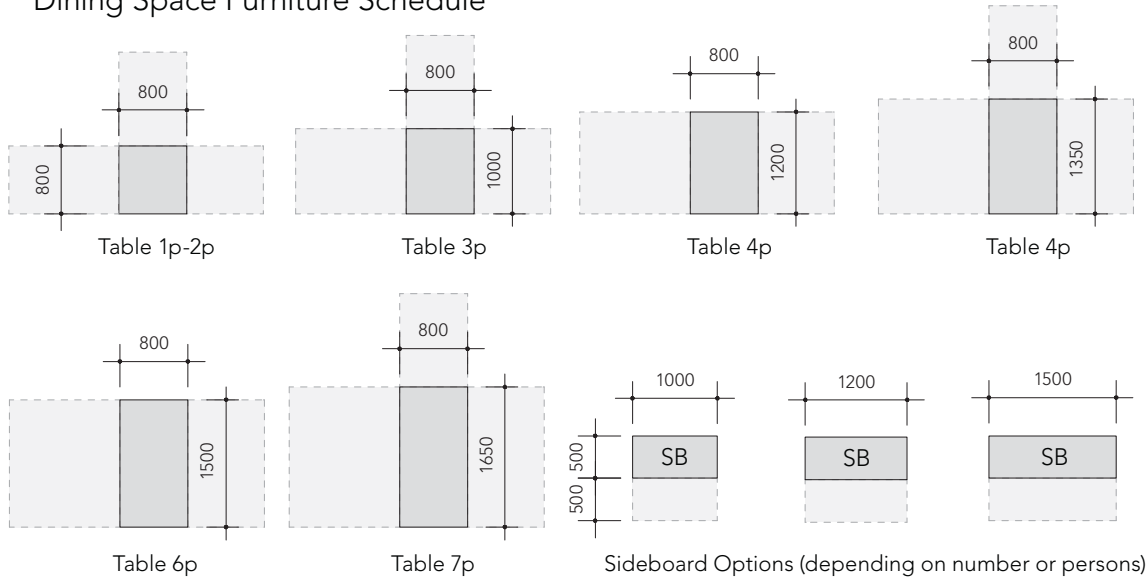

Circulation Zones

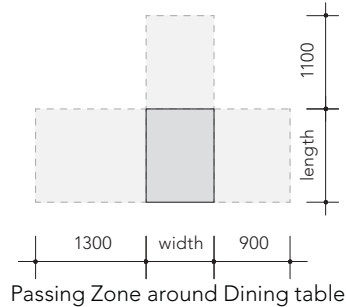

Living Space Furniture Schedule

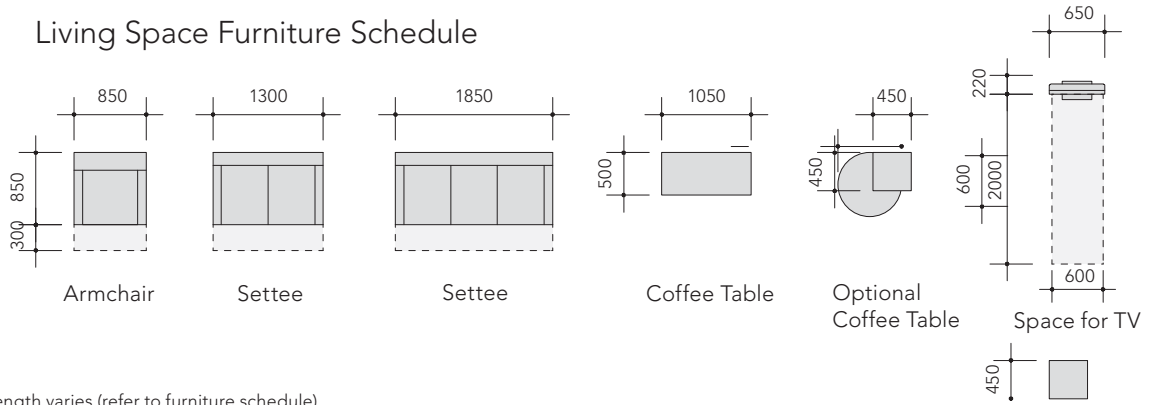

Length varies (refer to furniture schedule)

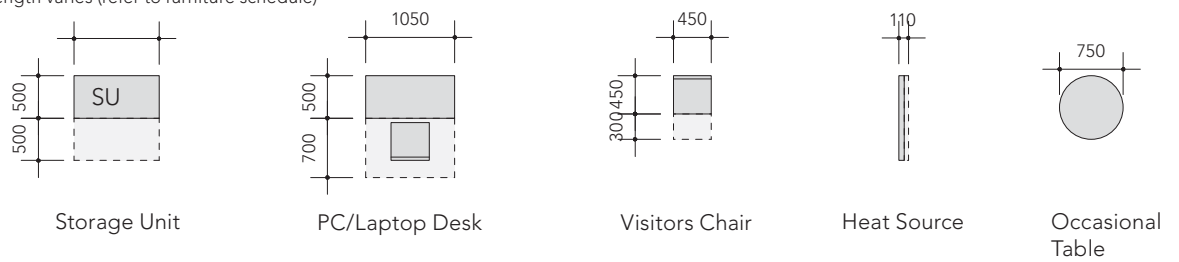

Bedroom Space Furniture Schedule

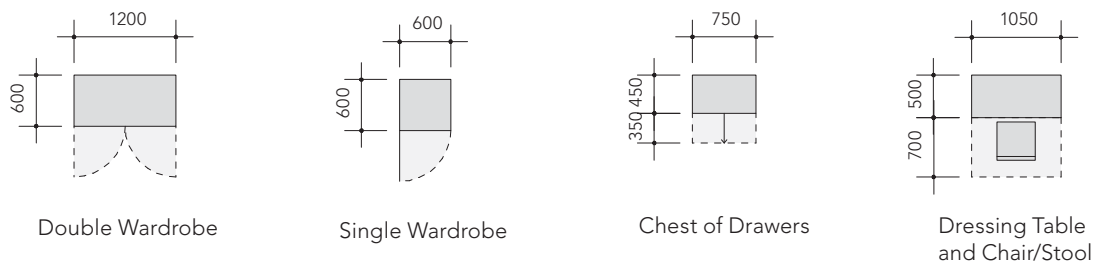
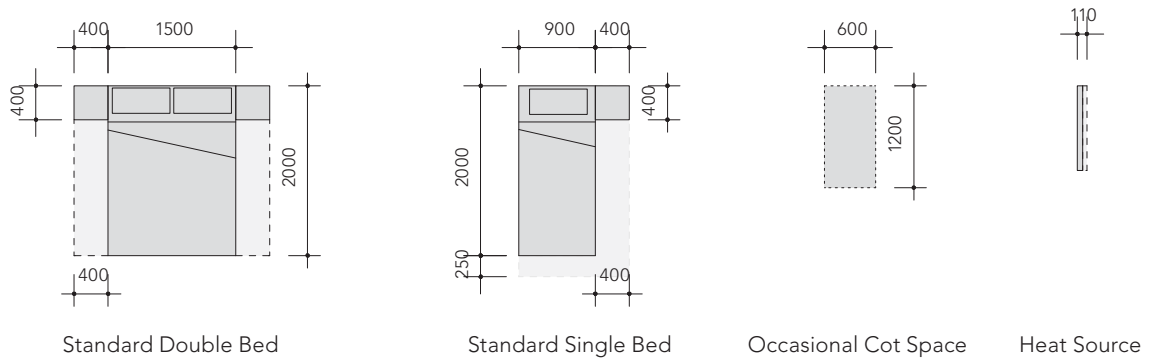

Activity Zones



Dressing/Drying Space 700x1100



Bed Making Space 400x Length of Bedspace



2000x2500
4p dwellings
and larger



1800x1200
1p-3p
dwellings

» Furniture Schedule *continued*

Type Of Space	Furniture Schedule	Furniture Sizes	Dwelling Size							
			mm	1p	2p	3p	4p	5p	6p	7p
Living Space	arm chair – combination to equal one seat/person	850x850	2	2	3	1	2	3	4	+1
	settee – 2 seat (optional; as above)	850x1300								
	settee – 3 seat (optional; as above)	850x1850				1	1	1	1	
	TV - [dim. Approx. 26" flat]	220x650	1	1	1	1	1	1	1	1
	coffee table	500x1050 or 750 diameter	1	1	1	1	1	1	1	1
	occasional table	450x450					1	1	1	1
	storage units	500x1000/ incrementally larger	1000	1000	1000	1500	2000	2000	2000	+
	PC/Laptop desk and chair	1050x500	1	1	1	1	1	1	1	1
	space for visitor's chair	450x450	2	2	2	2	2	2	2	2
Dining Space	dining chair	450x450	2	2	3	4	5	6	7	+
	dining table	800x800 / incrementally larger	800	800	1000	1200	1350	1500	1650	+
	sideboard (but not in dining kitchen)	450x1000 / incrementally larger	1000	1000	1000	1200	1500	1500	1500	+
Bedrooms										
Double Bedroom Optional	Double bed	2000x1500	n/a	1	1	1	1	1	1	1
	2 x single bed	2000x900								
	bedside table	400x400		2	2	2	2	2	2	2
	dressing table and chair/stool	500x1050		1	1	1	1	1	1	1
	chest of drawers	450 x750		1	1	1	1	1	1	1
	double wardrobe	600x1200		1	1	1	1	1	1	1
Twin Bedroom	2 x single bed	2000x900	n/a			2	2	2	2	2
	bedside table	400x400				2	2	2	2	2
	chest of drawers	450 x750				1	1	1	1	1
	table and chair/stool	500x1050				1	1	1	1	1
	double wardrobe	600x1200				1	1	1	1	1

Type Of Space	Furniture Schedule	Furniture Sizes	Dwelling Size							
Single Bedroom	single bed	2000x900	1		1	1	1	1	1	1
	bedside table	400x400	1		1	1	1	1	1	1
	chest of drawers	450 x750	1		1	1	1	1	1	1
	table and chair/stool	500x1050	1		1	1	1	1	1	1
	single wardrobe	600x600	1		1	1	1	1	1	1
	Total bed spaces		1	2	3	4	5	6	7	+
Kitchen			length in mm							
	1. sink top drainer	600x1000	1000	1000	1000	1000	1000	1000	1000	1000
	2. cooker space	600x600	600	600	600	600	600	600	600	600
	3. washing machine position/worktop	600x630	630	630	630	630	630	630	630	630
	4. other base units	600x length	600	1200	1600	1600	1600	2700	2700	+
	Optional 4a. dishwasher/ worktop- (included in 4)	600x length								
	5. ancillary equipment space	600x length					600	600	1200	1200
	6. fridge/freezer space	600x600	600	600	600	600	600	600	600	600
	7. hot water cylinder	600x600x1950[H]	600	600	600	600	600	600	600	600
	8. tray space	600x150	inc	inc	inc	inc	inc	inc	inc	inc
	9. recycling bins space	600x length	300	300	300	300	600	600	600	600
	10. length of fitments (items 1 to 9)		4330	4930	5330	5330	6230	7330	7930	+
	Note: Item 3,5 6,7,9 may be in adjacent rooms to the kitchen									
Bathroom	WC+cistern	500x700	1	1	1	1	1	1	1	1
	Bath	700x1700	1	1	1	1	1	1	1	1
	Wash hand basin	600x400	1	1	1	1	1	1	1	1
Optional	shower tray	750x750								
Separate Toilet	WC+cistern				1	1	1	1	1	1
	cloakroom basin				1	1	1	1	1	1
			area in m							
Storage	Cumulative total of built-in storage		1	1.5	2	2.5	3	3.5	4	0.5

Appendix 3 - Wheelchair Accessible Housing

The London Plan seeks to ensure that 10 per cent of all new housing is wheelchair accessible or easily adaptable for residents who are wheelchair users⁵⁹. Advice on implementing the policy is given by the London Plan SPG 'Accessible London: achieving an inclusive environment', which states that "this percentage should be applied to both market and affordable housing, should be evenly distributed throughout the development, and cater for a varying number of occupants⁶⁰." The GLA Best Practice Guidance 'Wheelchair Accessible Housing', 2007, offers guidance for designers on minimum standards for meeting the requirements for wheelchair accessible dwellings. The Best Practice Guidance is based on Habinteg Housing Association's 'Wheelchair Housing Design Guide', 2006 (the WHDG).

This appendix provides a checklist of key recommendations of the GLA Wheelchair Accessible Housing Best Practice Guidance. For each topic, a reference to further guidance in the WHDG is given in brackets. These references provide illustrative room layouts and will sometimes provide detail on spatial requirements necessary to ensure that the objectives below can be achieved. The guidance is intended to ensure that the ten per cent designated wheelchair accessible dwellings are suitable and easily adaptable for occupation by a wheelchair user at a later date. This means designing homes that can be adapted without the need for structural alteration, through minor modifications such as fixing grab rails, replacing kitchen units or replacing a bath with a shower, and designing homes that are large enough to accommodate the additional circulation and storage space requirements of wheelchair users, in all rooms and circulation areas.

Developers providing homes required to be fully fitted out for a wheelchair user from the outset (including those provided for RSLs receiving HCA housing grants) should refer to the detailed standards and

technical advice of the WHDG. References to further technical information contained in the WHDG are included next to the guidance text below.

Some London boroughs, including Waltham Forest, Greenwich and the SE London Partnership boroughs, have their own wheelchair user housing standards. Where these standards go beyond the accessibility and space standards of the GLA BPG, developers should comply with borough policy.

Design Considerations for Wheelchair Accessible Housing

Inclusion

An overriding principle is to aim for inclusive solutions, avoid differentiating by location, form and detailing, and providing a choice of size, aspect and floor level in multi-storey developments.

<h2>1. Moving Around Outside</h2>	
<p>Ensure a high degree of accessibility within the development.</p> <p>Designers should explain how wheelchair users and others with limited mobility will gain access to community facilities and public transport beyond the site and how convenient access will be achieved throughout the development, linking the entrance to the site and all entrances to dwellings and site facilities⁶¹. Wheelchair accessible dwellings are best sited in close proximity to local public transport, car parking and taxi drop-off points, as well as communal facilities such as gardens, gyms and play space. Connections from the development with local transport and other community facilities should also be wheelchair accessible.</p> <p>Footpaths Ensure that footpaths are smooth but slip resistant, of 1200mm minimum width, and have adequate space to negotiate obstacles, turn and pass (WHDG 1.2.1).</p>	<p>Gradients Ensure that length to gradient ratios of footpaths and other routes do not exceed 2000mm at 1 in 12 and 5000mm at 1 in 15. Where required, intermediate level landings should be at least 1200mm long (WHDG 1.2.3). Routes to entrances should not be steeper than 1 in 15 (WHDG 3.2.5).</p> <p>Cross Falls Ensure that cross falls to paving do not exceed 1 in 50, whether paving is dedicated to pedestrian use or shared with vehicles (WHDG 1.2.4).</p> <p>Crossings Ensure that crossings have flush junctions or shallow gradients. Avoid gratings and channels that could trap wheels or footrests. (WHDG 1.2.5)</p>
<h2>2. Using Outdoor Spaces</h2>	
<p>Ensure that spaces within the curtilage of the home are accessible, usable and, where appropriate, secure.</p> <p>Gardens Lay out gardens to provide an accessible route between the external door, external storage and external gate (WHDG 2.2.3).</p> <p>Where private back or side gardens are provided, ensure that gates have an 850mm clear opening and can be operated from each side by a wheelchair user (WHDG 2.2.1).</p>	<p>Balconies Provide nominally level access to balconies and useable space clear of any door swings (WHDG 2.2.2).</p> <p>Refuse Make suitable provision for refuse and recycling containers within a short distance of an external door, or ensure appropriate management provision (WHDG 2.2.4).</p>
<h2>3. Approaching the Home</h2>	
<p>Ensure ease of approach to the home by car, wheelchair or mobility scooter with good cover at the point of transfer, and good protection from the elements at the individual or common entrance.</p> <p>The parking strategy, including the provision and dimensions of bays, the management of the supply and future demand for bays and how their use will be enforced should be made clear in the Design and Access Statement. Designers should refer to BS8300:2009 for guidance about common areas of multi-storey developments, including circulation areas, doors, and lifts. Suitable designated parking spaces should be as close as possible to wheelchair accessible dwellings and under cover.</p> <p>Dwellings with a Direct External Entrance Provide a covered parking space for every wheelchair user dwelling (WHDG 3.2.1).</p> <p>Ensure that minimum clear dimensions are 3600mm wide x 5400mm long x 2200mm high and the parking area is paved with a slip resistant, smooth and nominally level surface. (WHDG 3.2.2)</p> <p>Dwellings with a Communal External Entrance Where there is no direct external ground-floor entrance, ensure parking provision in the form of designated parking space for each wheelchair user dwelling, off-street or</p>	<p>kerbside, nominally level that can enable transfer to and from vehicle. (WHDG 3.2.3)</p> <p>Ensure a smooth, slip resistant route to dwelling entrances. Ramps, where unavoidable, are not steeper than 1 in 15 and not longer than 5000mm. (WHDG 3.2.5)</p> <p>Entrance Landing Provide a level landing of minimum dimensions 1500mm x 1500mm. 1800mm by 1800mm is preferred. Ensure a 1200mm depth clear of any door swing. Provide side protection where the ground level is below the path or landing level (WHDG 3.2.6).</p> <p>Canopy at Entrance Provide a canopy of minimum dimensions 1200 x 1500mm extending beyond the door on the lock side and at a maximum height of 2300mm (WHDG 3.2.7).</p> <p>Lifts Where wheelchair dwellings are above the ground floor, lifts should be as detailed in BS 8300 (i.e. internal car dimensions of 1100 wide x 1400mm deep). A second lift should preferably be accessible to and from wheelchair user dwellings for use when the first or core lift is undergoing maintenance. (WHDG 3.2.9)</p>

<h4>4. Negotiating the Entrance Door</h4>	
<p>Ensure that the clear opening, approach space and threshold are suitable for wheelchair users.</p> <p>Door Provide effective clear width of at least 800mm (WHDG 4.2.1). Designers should consider increasing this to 900mm, or wider, particularly in relation to communal doors.</p> <p>Approach Space Provide a space beside the leading edge of the entrance</p>	<p>door of minimum 200mm for a door opening away from the wheelchair user and 300mm for a door opening towards a wheelchair user, extending 1800mm from face of door (WHDG 4.2.2).</p> <p>Threshold Provide a weather tight accessible detail with an upstand not exceeding 15mm. (WHDG 4.2.3).</p>
<h4>5. Entering and Leaving; Dealing with Callers</h4>	
<p>Ensure that the wheelchair user can:</p> <ul style="list-style-type: none"> enter the dwelling, manoeuvre an outdoor chair to allow transfer to an indoor chair, and reverse the process when leaving; leave the outdoor or indoor chair on charge; approach the entrance door to receive deliveries, retrieve post, open the door to visitors, manoeuvre, and return into living areas. <p>Lobby Where there is an entrance lobby or inner door, ensure there is adequate space to manoeuvre between doors (WHDG 5.2.5).</p>	<p>Turning Space Provide a turning space of 1800mm x 1500mm behind the closed door, clear of fittings and obstructions, and a 300mm clear space to the side of the leading edge of the door (WHDG 5.2.2).</p> <p>Transfer Space Provide a space of 1100mm x 1700mm to transfer to a second wheelchair, to store the first, and if necessary to leave it on charge, clear of circulation routes and the required approach to furniture and doors (WHDG 5.2.1).</p>
<h4>6. Negotiating the Secondary Door</h4>	
<p>Ensure a direct connection to external spaces by an easily operated, secure door, to provide access to private or shared gardens or balconies, and as an escape route in an emergency.</p> <p>External Landing Provide a nominally level landing 1500mm wide x 1500mm deep with a 1200mm space clear of the door swing (WHDG 6.2.1).</p>	<p>Door Provide effective clear width of 800mm to single or main leaf (WHDG 6.2.2).</p> <p>Approach Space Ensure there is adequate space to approach, manoeuvre and pass through the door on line (WHDG 6.2.3).</p> <p>Threshold Provide weather-tight, accessible detail (WHDG 6.2.4).</p>

7. Moving Around Inside; Storing Things

Ensure that wheelchair users can:

- conveniently manoeuvre, approach and negotiate all doors within circulation areas
- approach and use storage off circulation areas.

Some wheelchair users find open plan living and kitchen areas more convenient because there are fewer doors to negotiate. However, open plan arrangements should consider the noise from appliances often located in the kitchen.

Straight Passages

Ensure that passage widths or approaches, where no turning or door approach is required, are no less than 900mm wide clear of all obstructions except skirting (WHDG 7.2.1).

Head-on Approach to Doors in Passages

Ensure space beside latch edge of door, minimum 200mm on push side and minimum 300mm on pull side (WHDG 7.2.2).

Turning 90°

Ensure at right angles that passage width clear of all obstructions (except skirting) for the extent of the turn is no less than 1200mm width in one direction, and 900mm in the other; or 900mm in each direction in combination with an angle splayed by 300mm (WHDG 7.2.5).

Turning 180°

Ensure that passage widths or approaches to turn through 180° are no less than 1500mm clear of all obstructions (except skirting) for extent of manoeuvring space. (WHDG 7.2.4)

Effective clear widths for doors

Ensure 775mm minimum effective clear width. Increase where approach is at an angle (WHDG 7.2.6). Effective clear width of doors refers to the width between the face of the door or projecting fitting in the open position and the nearest point on the opposite frame or second door.

Doors at angles

Provide space to turn between doors at an angle to each other (At least 400mm from door to corner) (WHDG 7.2.8).

Sliding doors

Provide space beyond doorway at latch side for sideways approach and operation (300mm minimum) (WHDG 7.2.9).

Storage

Ensure that the depth and width of storage space, in combination with any shelving layout, provides optimum access to space and other stored items. Ensure that opening width of doors suits angled or head-on approach (WHDG 7.2.10).

8. Moving Between Levels Within the Dwelling

Where dwellings are designed on more than one floor level, ensure that there is provision for independent movement in a wheelchair between floors without the need to transfer, without compromising circulation or living space, and with all the rooms remaining accessible.

Through the Floor Lift

Flats and houses on more than one level that are designed to be capable of easy adaptation for wheelchair users should provide for the installation of a wheelchair accessible through-the-floor lift connecting a circulation space on the entrance level with a circulation space on the level of the main bedroom. A soft pocket or structural opening of

adequate size for a wheelchair accessible lift should be built in. Soft pockets should be identified clearly on the floor surface beneath the floor covering. The space for the through-the-floor lift could be used for storage until the need for a lift arises, provided any built in cupboards could be easily removed and enough storage is provided elsewhere in the dwelling.

Circulation

Provide adequate circulation space at each level to manoeuvre, call the lift, approach and open the lift door (WHDG 8.2.3).

9. Using Living Spaces

Ensure that a room can accommodate the usual range of furniture with space for a wheelchair-using member of the household to circulate and transfer from the wheelchair to seating.

Room Layout

Provide space for wheelchair users to approach furniture, circulate around it, transfer to seating and approach and operate doors, windows, equipment and control (WHDG 9.2.1).

<h2>10. Using the Kitchen</h2>	
<p>Ensure ease of approach to and use, from a wheelchair, of the sink, worktops, equipment, all appliances and controls and all storage essential to kitchen operations.</p> <p>Second to the bathroom, the design of the kitchen has the greatest impact on whether a wheelchair user can live independently at home. Individual requirements in the kitchen vary greatly but the key requirement for an adaptable kitchen is that it is large enough, and with sufficient space between the units, to enable a wheelchair user to manoeuvre freely and safely.</p>	<p>The hob, stove and sink should ideally be positioned on the same run of kitchen units, uninterrupted by doors, windows and main circulation routes. The windows should be accessible and operable by a person in a wheelchair. Ensure that the kitchen is designed so that adequate wheelchair accessible storage capacity can be retained following any future changes to provide clear knee space underneath the sink, hob or oven.</p> <p>Layout Provide clear manoeuvring space not less than 1800mm x 1500mm (WHDG 10.2.1).</p>
<h2>11. Using the Bathroom</h2>	
<p>The design of the bathroom is key to enabling independence and dignity for disabled people. The ability to manage most if not all toileting and bathing functions without assistance is highly desirable and is the foundation of independent living.</p> <p>Ensure that there is scope for independent approach and safe transfer to all bathroom fittings, and for independent use. To ensure independent use of the WC, enough space should be available to approach it head-on, obliquely or to make a side-transfer. Designers should refer to the illustrations in section 11 of the WHDG for further guidance on the spatial requirements of wheelchair accessible bathrooms.</p> <p>Bathroom In all dwellings provide fully accessible bathroom with WC, basin, and installed level-access shower with provision for bath in place of shower if needed, with flexible or easily adapted services (WHDG 11.2.1).</p> <p>Access from Bedroom Ensure provision for direct access from main bedroom (WHDG 11.2.2). An en-suite arrangement or a full height knock-out panel between the main bedroom and the bathroom allows for direct access and the installation of a ceiling-mounted hoist, if required.</p> <p>Second WC In dwellings of four or more persons, provide fully accessible second WC with basin, and hand the transfer space opposite to the handing of the main WC to provide both left-handed</p>	<p>and right-handed transfer options within the dwelling (WHDG 11.2.3).</p> <p>Layout Ensure independent approach/transfer to and use of all fittings, including manoeuvring space clear of fittings (WHDG 11.2.4).</p> <p>Shower Where fully installed, detail to be fully accessible comprising drained floor, reachable and usable controls and scope for suitable water containment or suitable enclosure (WHDG 11.2.6). Many wheelchair users consider the shower area of 1000 x 1000mm described in the WHDG too small; 1200 x 1200mm is more convenient. Under-floor heating in a bathroom with a level access shower dries the floor more quickly thereby improving safety.</p> <p>Bath Where provided select bath and taps, position and detail to allow a range of transfers, access to and operation of taps (WHDG 11.2.7). Corner taps on the outer side of baths are most desirable according to BS 8300:2009, Approved Document Part M and the WHDG.</p> <p>Supports Ensure that walls and ceiling are adequate for adjustable height basins and subsequent fixing of hoists, seats, supports and other fittings (WHDG 11.2.10).</p>
<h2>12. Using Bedrooms</h2>	
<p>Ensure that there is space in all bedrooms to accommodate the normal range of bedroom furniture and for the wheelchair-using member of the household to enter, approach and transfer to beds, approach and use other furniture and operate windows.</p> <p>Layouts Provide bedroom layouts to ensure access to both sides of beds in double bedrooms and outer side of beds in single bedrooms, access to other furniture and to window (WHDG 12.2.1).</p>	<p>Door Make provision for connection between main bedroom and bathroom by means of full-height knock-out panel, a door with panel over in full-height frame or fully detailed door (WHDG 12.2.3).</p> <p>Hoist Make provision for future ceiling track hoist installation in main bedroom - strengthen ceiling to allow run into bathroom (WHDG 12.2.4).</p>

13. Internal Doors	
All internal doors, including those to storage spaces, can be operated conveniently. This means the door construction should allow for large pull handles and other fittings to be added to suit individual requirements.	<p>Construction Ensure that door construction permits subsequent fixing of pulls or other fittings (WHDG 13.2.1).</p>
14. Windows	
Ensure independent control of opening windows, passive and mechanical ventilation to requirements of Building Regulations and to reasonable level of comfort. Ensure a balance of daylight, views out, privacy and security.	<p>Approach Ensure that a wheelchair user can approach each window to operate controls for opening and ventilation (WHDG 14.2.1).</p> <p>Transoms Avoid full-width transoms (horizontal divisions) between 800 and 1500mm high (WHDG 14.2.6).</p>

Appendix 4 - Definitions

Adaptable: The ability to modify spaces for a new use or purpose by altering the physical fabric of the building, such as removing or moving internal walls or extending a property. Families: Households with at least one child under 18 years old.

Family housing: Two-bedroom, three-person homes and homes for larger households.

Flexible: The ability for spaces to accommodate a range of uses and respond to altered circumstances.

Gross Internal Area: (GIA) Gross Internal Area is the area of a building measured to the internal face of the perimeter walls at each floor level. Measurement should be in accordance with the RICS Guidance Note 'Code of Measuring Practice' 6th Edition. The Gross Internal Area includes floor area of habitable and non-habitable rooms plus circulation, plus area taken up by internal partitions. It does not include the area of external private amenity space.

Specifics of what is and is not to be included in the measurement of internal space when undertaking the dwelling space assessment. Not to be included:

- Perimeter wall thicknesses and external projections
- Central lobby areas, passageways and other communal areas shared with other units.
- Any space where the height to the ceiling is less than 1.5m (e.g. elements of rooms with sloping ceilings, external dustbin enclosures, etc.)
- Porches, covered ways, etc
- Balconies (private, escape and access) and decks
- Voids and air wells
- Non-habitable basements, attics, thermal buffer zones or sheds.
- External storage space (see unit layout for this requirement)
- All space for purposes other than housing (e.g. garages, commercial premises etc).
- Conservatories not forming an integral part of the habitable space

To be included:

- Floor area measured between the inside faces of the finished enclosing walls of each unit, including the space taken up by the following:
 - Private staircases
 - Partitions
 - Internal walls
 - Heating appliances
- Internal chimney breast projections.
- Internal porches forming an integral part of the habitable space
- Internal storage space greater than 1.5m in height
- Conservatories forming an integral part of the habitable space

Habitable Room: Habitable rooms provide the living accommodation of the dwelling. They include living room, dining room, study, home office, conservatory, bedroom etc. They exclude the bathroom, WC, utility room, store room and circulation space. A kitchen is not a habitable room unless it provides space for dining.

Higher density: Densities exceeding 80 dwellings per hectare or 250 habitable rooms per hectare.

Lifetime Homes: This refers to 16 design criteria that together create a flexible blueprint for accessible and adaptable housing in any setting. The standard is managed by Habinteg Housing Association and the criteria are set out in full on www.lifetimehomes.org.uk. Since 2004 the London Plan has required all new housing in London to meet the Lifetime Homes standards.

Secured By Design: Secured by Design (SBD) is a UK Police flagship initiative that advocates designing out crime to promote safer neighbourhoods.

Tenure Blind: The principle that dwellings of different tenures should be designed to be indistinguishable.

Appendix 5 – References

- Accommodating Diversity: Housing Design in a Multicultural Society, National Housing Federation 1998
- By Design - urban design and the planning system: towards better practice, DTLR, 2001
- Capital Gains: Making high density housing work in London, London Housing Federation, May 2002
- Car parking: what works where, English Partnerships and Design for Homes, 2006
- Code for Sustainable Homes Technical Guidance, DCLG, October 2008
- Creating Excellent Buildings: A guide for clients, CABE, October 2003
- Crowded House: cramped living in England's housing, Shelter, October 2004
- Delivering Excellent Places: Building for Life, CABE/HBF, 2007 edition
- Design and Quality Standards, Housing Corporation, April 2007
- Design and Quality Strategy, Housing Corporation, April 2007
- Design of Accessible Housing: Lifetime Homes Code of Practice, BSI Draft for Development DD266:2007
- Draft Replacement London Plan, GLA, October 2009
- English Partnerships' Quality Standards: Delivering Quality, English Partnerships, Revised November 2007
- Higher Density Housing for families: a design and specification guide, London Housing Federation, October 2004
- Homes for Today & Tomorrow, Ministry of Housing and Local Government, 1961
- Housing for a Compact City, GLA, February 2003
- Housing our Ageing Population Panel for Innovation Report (HAPPI), HCA, 2009
- Housing Quality Indicators Form v4, Housing Corporation, April 2008
- Housing Space Standards, HATC for the GLA, August 2006
- Inclusive Design Toolkit, LDA, 2009
- London Plan Best Practice Guidance on Wheelchair Accessible Housing, GLA, September 2007
- London Plan Supplementary Planning Guidance (SPG) on Achieving an Inclusive Environment, GLA, April 2004
- London Plan SPG on Providing for Children and Young People's Play and Informal Recreation, GLA, March 2008
- London Plan SPG on Sustainable Design and Construction, GLA, May 2006
- The Mayor's Housing Strategy, GLA, February 2010
- Perceptions of Privacy and Density in Housing, Design for Homes, 2003
- Recommendations for Living at Superdensity, Design for Homes, June 2007
- Rubbish in, Resources out, GLA and Design for London, 2008
- Secured by Design New Homes, Association of Chief Police Officers, 2009
- Standards and Quality in Development: A good practice guide (2nd edition), National Housing Federation, July 2008
- The London Housing Strategy: Draft for public consultation, GLA, May 2009
- The London Plan: Consolidated with alterations since 2004, GLA, February 2008
- Urban Design Compendium, English Partnerships, November 2007
- What Homebuyers Want, CABE, 2005
- Wheelchair Housing Design Guide, Habinteg Housing Association, February 2006
- Wheelchair Housing Best Practice Guide, GLA, September 2007

Credits

Preparation of this guidance has been led by Design for London on behalf of the Mayor of London, with strong input from their parent organisation the London Development Agency, and from the Greater London Authority and the Homes and Communities Agency London region. Thanks are due to a huge range of organisations and individuals who have participated in the process. These include the following:

Consultant Team

Deborah Mathieson
Emily Greeves Architects
Kieran Long
Levitt Bernstein
Mae Architects
Navigant Consulting
Proctor Matthews Architects
PRP Architects
Urban Initiatives

Significant Contributors

Adams Kara Taylor
Allford Hall Monaghan Morris
Andrew Drury, HATC Ltd
Beyond Green
Broadway Malyan
Chris Goodman
Commission for Architecture and the Built Environment
Cyril Sweett
David Bonnett Associates
Davis Langdon
Design for Homes
Design for London Advisory Group
General Public Agency
Graham Harrington
GVA Grimley
Habinteg
HTA Architects
Lifschutz Davidson Sandilands
London Fire Brigade
Maccreevor Lavington Architects
Metropolitan Police Service
National Housing Federation, London region

Pitman Tozer Architects
Pollard Thomas Edwards Architects
RIBA Housing Group
Richard Rogers
Riches Hawley Mikhail Architects
Robin Murray
Royal College of Art
Sergison Bates Architects
Sheppard Robson
Stephen Marshall Architects
The Mayors Design Advisory Panel
Transport for London

Many London Boroughs including:

LB Waltham Forest
LB Southwark
LB Kingston
LB Westminster
LB Croydon

Several developers and housing associations including:

East Thames Group
Octavia Housing

With thanks also to others who have contributed to this guidance through participation at workshops and seminars, and to more than one hundred groups and individuals who responded formally to the consultation.

Graphic design by Atwork

